

## Īpašības

Modelis	Tīrītājs
Slīdes ātrums max.	0,5 m/s
Temperatūra min.	-30 °C
Temperatūra max.	110 °C
Darba vides	Minerāleļļas Ūdens emulsijas
Montāža	Tīrītāju izveidot elipsveida formā un iespiest rievā
Materiāls	NBR 90°, Šora cietība A
Izmantošana	Hidrauliskā sistēma

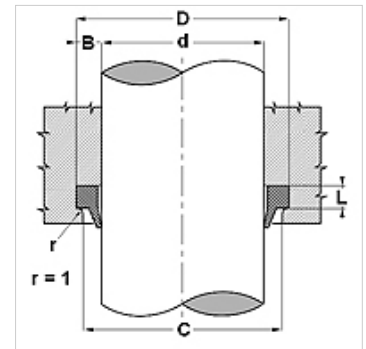

Toleranz / Tolerance			
d	D	L	C
h11	+0,20 0	+0,10 0	+0,20 0



## Apraksts

vienkārša montāža  
Vienkāršs risinājums.  
Nepieciešams ļoti maz vietas

## Pasūtījuma norādes

Iespējami citi materiāli: FPM.

## Izstrādājums

Apzīmējums	d (mm)	D (mm)	L (mm)	C (mm)
WRM 470 70	12,0	18,6	3,8	15,0
WRM 590 82	15,0	21,6	3,8	18,0
WRM 620 87	16,0	22,6	3,8	19,0
WRM 700 94	18,0	24,6	3,8	21,0
WRM 781 10	20,0	28,6	5,3	23,0
WRM 861 18	22,0	30,6	5,3	25,0
WRM 981 29	25,0	33,6	5,3	28,0
WRM 102 133	26,0	34,6	5,3	29,0
WRM 106 137	27,0	35,6	5,3	30,0
WRM 110 141	28,0	36,6	5,3	31,0
WRM 118 149	30,0	38,6	5,3	33,0
WRM 125 157	32,0	40,6	5,3	35,0
WRM 137 169	35,0	43,6	5,3	38,0
WRM 141 173	36,0	44,6	5,3	39,0
WRM 157 188	40,0	48,6	5,3	43,0
WRM 165 196	42,0	50,6	5,3	45,0
WRM 177 208	45,0	53,6	5,3	48,0
WRM 177 216	45,0	55,6	5,3	49,0
WRM 196 228	50,0	58,6	5,3	53,0
WRM 196 236	50,0	60,6	5,3	54,0
WRM 216 248	55,0	63,6	5,3	58,0
WRM 220 251	56,0	64,6	5,3	59,0
WRM 220 259	56,0	66,6	5,3	60,0
WRM 236 267	60,0	68,6	5,3	63,0
WRM 248 279	63,0	71,6	5,3	66,0
WRM 255 287	65,0	73,6	5,3	68,0
WRM 255 295	65,0	75,6	5,3	69,0
WRM 275 307	70,0	78,6	5,3	73,0
WRM 275 314	70,0	80,6	5,3	74,0
WRM 275 322	70,0	82,2	7,1	76,0
WRM 283 317	72,0	80,6	5,3	75,0
WRM 295 345	75,0	87,2	7,1	81,0
WRM 301 348	76,5	88,7	7,1	82,5
WRM 307 362	78,0	92,2	7,1	85,0
WRM 314 346	80,0	88,6	5,3	83,0
WRM 314 362	80,0	92,2	7,1	86,0
WRM 334 366	85,0	93,6	5,3	88,0
WRM 346 393	88,0	100,2	7,1	94,0
WRM 354 401	90,0	102,2	7,1	96,0
WRM 374 421	95,0	107,2	7,1	101,0



## Izstrādājums

Apzīmējums	d (mm)	D (mm)	L (mm)	C (mm)
WRM 393 440	100,0	112,2	7,1	106,0
WRM 413 460	105,0	117,2	7,1	111,0
WRM 433 480	110,0	122,2	7,1	116,0
WRM 452 500	115,0	127,2	7,1	121,0
WRM 472 504	120,0	128,0	7,0	123,0
WRM 472 519	120,0	132,2	7,1	126,0
WRM 492 539	125,0	137,2	7,1	131,0
WRM 492 551	125,0	140,2	10,1	132,0
WRM 531 578	135,0	147,2	7,1	141,0
WRM 551 598	140,0	152,2	7,1	146,0
WRM 551 610	140,0	155,2	10,1	147,0
WRM 570 618	145,0	157,2	7,1	151,0
WRM 590 637	150,0	162,2	7,1	156,0
WRM 629 661	160,0	168,6	5,3	163,0
WRM 629 688	160,0	175,2	10,1	168,0
WRM 673 720	171,0	183,0	6,3	176,0
WRM 688 744	175,0	189,2	7,1	182,0
WRM 708 767	180,0	195,0	10,1	188,0
WRM 708 787	180,0	200,0	10,1	190,0
WRM 787 847	200,0	215,0	10,1	207,0
WRM 787 866	200,0	220,0	10,1	210,0
WRM 102 411 02	260,0	280,0	10,2	270,0