

## Eigenschappen

<b>Aansluiting 1</b>	Metrische buitendraad cilindrisch
<b>Afdichtingsvorm 1</b>	24° binnenconus
<b>Aansluiting 2</b>	Metrische buitendraad cilindrisch
<b>Afdichtingsvorm 2</b>	24° binnenconus
<b>Constructie</b>	Draaikoppeling (schotconnector)
<b>Constructie-toevoeging</b>	Kogellager
<b>Uitvoering</b>	recht
<b>Leveromvang</b>	Buissok (zonder wartelmoer en snijring)
<b>Materiaal</b>	Staal
<b>Oppervlakbescherming</b>	Galvanisch gecoat

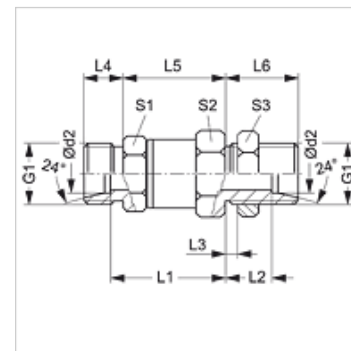

## Aanwijzing

Aanwijzingen voor de montage, inbouw, drukbelasting en toegestane werktemperaturen staan in de technische informatie voor schroefdraadpijpverbindingen.

## Artikel

Aanduiding	Serie	Werkdruk bar	Ø d2 (mm)	G1	L1 (mm)	L2 (mm)	L3 (mm)	L4 (mm)	L5 (mm)	L6 (mm)	S1	S2	S3
DGS NW 06 HL	L	PN 315	8	M 14 x 1,5	40,0	16,0	5	10	37,0	23,0	19	22	17
DGS NW 08 HL	L	PN 315	10	M 16 x 1,5	50,0	16,0	5	11	46,0	23,0	24	30	22
DGS NW 10 HL	L	PN 315	12	M 18 x 1,5	50,0	16,0	5	11	46,0	23,0	24	30	24
DGS NW 13 HL	L	PN 315	15	M 22 x 1,5	51,0	19,0	5	12	46,0	26,0	24	30	30
DGS NW 16 HL	L	PN 315	18	M 26 x 1,5	61,0	28,0	15	12	56,5	35,5	36	41	36
DGS NW 20 HL	L	PN 160	22	M 30 x 2	63,0	30,5	15	14	56,5	38,0	36	41	41
DGS NW 25 HL	L	PN 160	28	M 36 x 2	75,0	31,0	15	14	68,5	38,5	55	60	46
DGS NW 32 HL	L	PN 160	35	M 45 x 2	74,0	31,5	15	16	68,5	42,0	55	60	55
DGS NW 04 HS H	S	PN 500	8	M 16 x 1,5	42,0	16,0	5	12	37,0	23,0	19	22	22
DGS NW 08 HS H	S	PN 500	12	M 20 x 1,5	52,5	15,5	5	12	48,0	23,0	24	30	27
DGS NW 13 HS H	S	PN 400	16	M 24 x 1,5	51,5	17,5	5	14	46,0	26,0	24	30	32
DGS NW 16 HS H	S	PN 400	20	M 30 x 2	65,5	28,5	15	16	60,0	39,0	36	41	41
DGS NW 20 HS H	S	PN 400	25	M 36 x 2	66,0	30,0	15	18	60,0	42,0	36	41	46
DGS NW 25 HS H	S	PN 400	30	M 42 x 2	75,5	30,5	15	22	69,0	44,0	55	60	50

Serie: LL = zeer licht L = licht S = zwaar - PN = nominale druk PB = max. werkdruk - Ø d2 = buitendiameter buis