

Eigenschappen

Aansluiting 1	NPT-binnendraad
Afdichtingsvorm 1	draaddichtend
Aansluiting 2	Metrische buitendraad cilindrisch
Afdichtingsvorm 2	24° binnenconus
Constructie	Opschroefverbinding
Uitvoering	recht
Leveromvang	Sok met wartelmoer en snijring
Materiaal	RVS

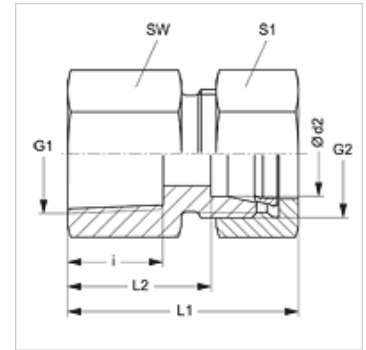

Aanwijzing

Aanwijzingen voor de montage, inbouw, drukbelasting en toegestane werktemperaturen staan in de technische informatie voor schroefdraadpijpvormingen.

Artikel

Aanduiding	Serie	Werkdruk bar	Ø d2 (mm)	G1	G2	i (mm)	L1 (mm)	L2 (mm)	SW (mm)	S1
GAN NW 04 HL VA	L	PN 315	6	1/8" -27 NPT	M 12 x 1,5	11,6	34,0	19,0	14	14
GAN NW 04 HL 1/4 VA	L	PN 315	6	1/4" -18 NPT	M 12 x 1,5	16,4	38,0	23,5	19	14
GAN NW 06 HL VA	L	PN 315	8	1/4" -18 NPT	M 14 x 1,5	16,4	38,0	23,5	19	17
GAN NW 08 HL VA	L	PN 315	10	1/4" -18 NPT	M 16 x 1,5	16,4	39,0	24,0	19	19
GAN NW 08 HL 1/2 VA	L	PN 315	10	1/2" -14 NPT	M 16 x 1,5	22,6	38,0	26,0	27	19
GAN NW 10 HL 1/4 VA	L	PN 315	12	1/4" -18 NPT	M 18 x 1,5	16,4	43,0	23,5	19	19
GAN NW 10 HL VA	L	PN 315	12	3/8" -18 NPT	M 18 x 1,5	17,4	42,0	27,0	24	22
GAN NW 10 HL 1/2 VA	L	PN 315	12	1/2" -14 NPT	M 18 x 1,5	22,6	47,0	32,0	27	22
GAN NW 13 HL VA	L	PN 315	15	1/2" -14 NPT	M 22 x 1,5	22,6	48,0	33,0	27	27
GAN NW 16 HL VA	L	PN 315	18	1/2" -14 NPT	M 26 x 1,5	22,6	49,0	32,5	27	32
GAN NW 20 HL VA	L	PN 160	22	3/4" -14 NPT	M 30 x 2	23,1	52,0	35,5	36	36
GAN NW 25 HL VA	L	PN 160	28	1" -11,5 NPT	M 36 x 2	27,8	57,0	40,5	41	41
GAN NW 32 HL VA	L	PN 160	35	1,1/4" -11,5 NPT	M 45 x 2	28,3	62,0	40,5	55	50
GAN NW 40 HL VA	L	PN 160	42	1,1/2" -11,5 NPT	M 52 x 2	28,3	65,0	42,0	60	60
GAN NW 03 HS VA	S	PN 630	6	1/4" -18 NPT	M 14 x 1,5	16,4	41,0	26,0	19	17
GAN NW 04 HS VA	S	PN 630	8	1/4" -18 NPT	M 16 x 1,5	16,4	41,0	26,0	19	19
GAN NW 06 HS VA	S	PN 630	10	3/8" -18 NPT	M 18 x 1,5	17,4	44,0	27,0	24	22
GAN NW 08 HS VA	S	PN 630	12	3/8" -18 NPT	M 20 x 1,5	17,4	44,0	27,5	24	24
GAN NW 08 HS 1/2 VA	S	PN 630	12	1/2" -14 NPT	M 20 x 1,5	22,6	50,0	33,5	27	24
GAN NW 10 HS VA	S	PN 630	14	1/2" -14 NPT	M 22 x 1,5	22,6	53,0	35,0	27	27
GAN NW 13 HS VA	S	PN 400	16	1/2" -14 NPT	M 24 x 1,5	22,6	50,0	34,5	27	30
GAN NW 16 HS VA	S	PN 400	20	3/4" -14 NPT	M 30 x 2	23,1	57,0	35,5	32	36
GAN NW 20 HS VA	S	PN 400	25	1" -11,5 NPT	M 36 x 2	27,8	65,0	41,0	41	46
GAN NW 25 HS VA	S	PN 400	30	1,1/4" -11,5 NPT	M 42 x 2	28,3	70,0	43,5	55	50
GAN NW 32 HS VA	S	PN 315	38	1,1/2" -11,5 NPT	M 52 x 2	28,3	74,0	43,0	60	60

Serie: LL = zeer licht L = licht S = zwaar - PN = nominale druk PB = max. werkdruk - Ø d2 = buitendiameter buis

Productvarianten

XGAN VA Opschroefverbinding, Buissok (zonder wartelmoer en snijring)