

# T

## Koppeling, T-vorm

### Eigenschappen

<b>Aansluiting 1 - 3</b>	Metrische buitendraad cilindrisch
<b>Afdichtingsvorm 1 - 3</b>	24° binnenconus
<b>Constructie</b>	Koppeling
<b>Uitvoering</b>	T-vorm
<b>Norm</b>	DIN 2353 ISO 8434-1
<b>Leveromvang</b>	Sok met wartelmoer en snijring
<b>Materiaal</b>	Staal
<b>Oppervlakbescherming</b>	Galvanisch gecoat

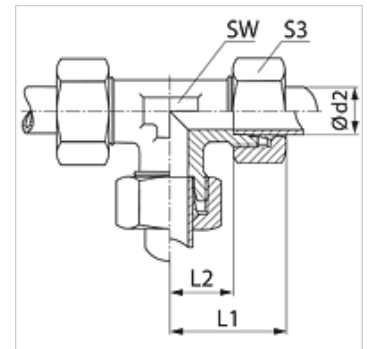

### Aanwijzing

Aanwijzingen voor de montage, inbouw, drukbelasting en toegestane werktemperaturen staan in de technische informatie voor schroefdraadpijpvbindingen.

### Artikel

Aanduiding	Serie	Werkdruk bar	Ø d2 (mm)	L1 (mm)	L2 (mm)	SW (mm)	S3
T 04 LL	LL	PN 100	4	21	11,0	9	10
T 05 LL	LL	PN 100	5	21	9,5	11	12
T 06 LL	LL	PN 100	6	21	9,5	9	12
T 08 LL	LL	PN 100	8	23	11,5	12	14
T 10 LL	LL	PN 100	10	27	15,5	14	17
T 12 LL	LL	PN 100	12	27	15,0	17	19
T 16 LL	LL	PN 100	16	40	23,0	19	22
T NW 04 HL	L	PN 315	6	27	12,0	12	14
T NW 06 HL	L	PN 315	8	29	14,0	12	17
T NW 08 HL	L	PN 315	10	30	15,0	14	19
T NW 10 HL	L	PN 315	12	32	17,0	17	22
T NW 13 HL	L	PN 315	15	36	21,0	19	27
T NW 16 HL	L	PN 315	18	40	23,5	24	32
T NW 20 HL	L	PN 160	22	44	27,5	27	36
T NW 25 HL	L	PN 160	28	47	30,5	36	41
T NW 32 HL	L	PN 160	35	56	34,5	41	50
T NW 40 HL	L	PN 160	42	63	40,0	50	60
T NW 03 HS	S	PN 630	6	31	16,0	12	17
T NW 04 HS	S	PN 630	8	32	17,0	14	19
T NW 06 HS	S	PN 630	10	34	17,5	17	22
T NW 08 HS	S	PN 630	12	38	21,5	17	24
T NW 10 HS	S	PN 630	14	40	22,0	19	27
T NW 13 HS	S	PN 400	16	43	24,5	24	30
T NW 16 HS	S	PN 400	20	48	26,5	27	36
T NW 20 HS	S	PN 400	25	54	30,0	36	46
T NW 25 HS	S	PN 400	30	62	35,5	41	50
T NW 32 HS	S	PN 315	38	72	41,0	50	60

Serie: LL = zeer licht L = licht S = zwaar - PN = nominale druk PB = max. werkdruk - Ø d2 = buitendiameter buis

### Productvarianten

<b>T MG</b>	Koppeling, T-vorm, Messing
<b>T VA</b>	Koppeling, T-vorm, RVS
<b>XT</b>	Koppeling, T-vorm, Staal