

Eigenschappen

Aansluiting 1	Metrische moerdraad
Afdichtingsvorm 1	Buissok met snijring
Aansluiting 2 + 3	Metrische buitendraad cilindrisch
Afdichtingsvorm 2 + 3	24° binnenconus
Constructie	Koppeling richting instelbaar
Uitvoering	T-vorm
Norm	DIN 2353 ISO 8434-1
Leveromvang	Sok met wartelmoer en snijring
Materiaal	Staal
Oppervlakbescherming	Galvanisch gecoat

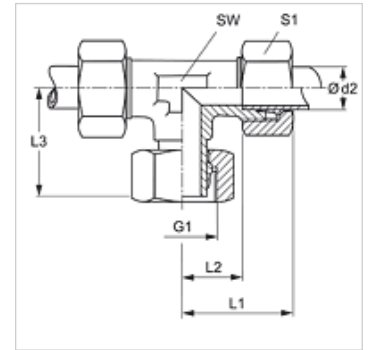

Aanwijzing

Aanwijzingen voor de montage, inbouw, drukbelasting en toegestane werktemperaturen staan in de technische informatie voor schroefdraadpijpvverbindingen.

Artikel

Aanduiding	Serie	Werkdruk bar	Ø d2 (mm)	G1	L1 (mm)	L2 (mm)	L3 (mm)	SW (mm)	S1
VET 16 LL	LL	PN 100	16	M 22 x 1,5	36	21,0	33,0	19	27
VET NW 04 HL	L	PN 315	6	M 12 x 1,5	27	12,0	26,0	12	14
VET NW 06 HL	L	PN 315	8	M 14 x 1,5	29	14,0	27,0	12	17
VET NW 08 HL	L	PN 315	10	M 16 x 1,5	30	15,0	28,5	14	19
VET NW 10 HL	L	PN 315	12	M 18 x 1,5	32	17,0	29,0	17	22
VET NW 13 HL	L	PN 315	15	M 22 x 1,5	36	21,0	32,0	19	27
VET NW 16 HL	L	PN 315	18	M 26 x 1,5	40	23,5	36,0	24	32
VET NW 20 HL	L	PN 160	22	M 30 x 2	44	27,5	38,0	27	36
VET NW 25 HL	L	PN 160	28	M 36 x 2	47	30,5	41,5	36	41
VET NW 32 HL	L	PN 160	35	M 45 x 2	56	34,5	51,0	41	50
VET NW 40 HL	L	PN 160	42	M 52 x 2	63	40,0	56,0	50	60
VET NW 03 HS	S	PN 630	6	M 14 x 1,5	31	16,0	27,0	12	17
VET NW 04 HS	S	PN 630	8	M 16 x 1,5	32	17,0	27,0	14	19
VET NW 06 HS	S	PN 630	10	M 18 x 1,5	34	17,5	29,5	17	22
VET NW 08 HS	S	PN 630	12	M 20 x 1,5	38	21,5	30,5	17	24
VET NW 10 HS	S	PN 630	14	M 22 x 1,5	40	22,0	34,5	19	27
VET NW 13 HS	S	PN 400	16	M 24 x 1,5	43	24,5	36,0	24	30
VET NW 16 HS	S	PN 400	20	M 30 x 2	48	26,5	44,0	27	36
VET NW 20 HS	S	PN 400	25	M 36 x 2	54	30,0	49,5	36	46
VET NW 25 HS	S	PN 400	30	M 42 x 2	62	36,5	55,0	41	50
VET NW 32 HS	S	PN 315	38	M 52 x 2	72	41,0	63,0	50	60

Serie: LL = zeer licht L = licht S = zwaar - PN = nominale druk PB = max. werkdruk - Ø d2 = buitendiameter buis

Productvarianten

VET MG	Koppeling, T-vorm, Messing
VET VA	Koppeling, T-vorm, RVS
XVET	Koppeling, T-vorm, Staal