

## Eigenschappen

Constructie	Drukkring voor kraagaansluiting
Materiaal	Staal
Oppervlakbescherming	Galvanisch gecoat

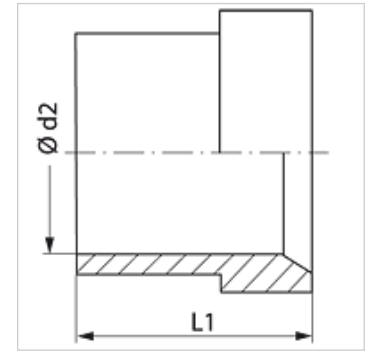

## Artikel

Aanduiding	Serie	Werkdruk bar	Ø d2 (mm)	L1 (mm)
DRD 06	L / S	PN 630	6	10,5
DRD 08	L / S	PN 630	8	11,0
DRD 10	L / S	PN 630	10	12,5
DRD 12	L / S	PN 630	12	13,0
DRD 15	L	PN 400	15	14,0
DRD 18	L	PN 315	18	14,5
DRD 22	L	PN 315	22	18,0
DRD 28	L	PN 250	28	17,0
DRD 35	L	PN 250	35	19,0
DRD 42	L	PN 250	42	21,0
DRD 14	S	PN 630	14	14,5
DRD 16	S	PN 400	16	17,0
DRD 20	S	PN 400	20	17,5
DRD 25	S	PN 400	25	20,0
DRD 30	S	PN 400	30	21,5
DRD 38	S	PN 315	38	26,5

PN = nominale druk PB = max. werkdruk – Serie: LL = zeer licht L = licht S = zwaar

## Productvarianten

DRD VA Drukkring voor kraagaansluiting, RVS