

Eigenschappen

Aansluiting 1	metrische buitendraad conisch
Afdichtingsvorm 1	draaddichtend
Aansluiting 2	Metrische buitendraad cilindrisch
Afdichtingsvorm 2	24° binnenconus
Constructie	Inschroefverbinding
Uitvoering	recht
Norm	DIN 2353 ISO 8434-1
Leveromvang	Buissok (zonder wartelmoer en snijring)
Materiaal	Staal
Oppervlakbescherming	Galvanisch gecoat

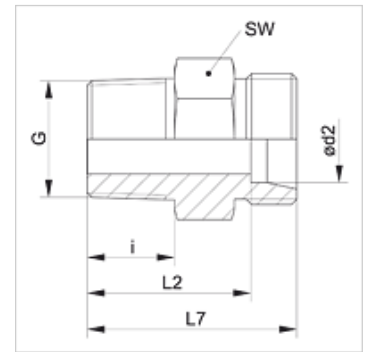

Aanwijzing

Aanwijzingen voor de montage, inbouw, drukbelasting en toegestane werktemperaturen staan in de technische informatie voor schroefdraadpijpvverbindingen.

Artikel

Aanduiding	Serie	Werkdruk bar	Ø d2 (mm)	G	i (mm)	L2 (mm)	L7 (mm)	SW (mm)
XVM 04 LL 6	LL	PN 100	4	M 6 x 1 K	8	16,0	20	9
XVM 04 LL	LL	PN 100	4	M 8 x 1 K	8	16,0	20	9
XVM 04 LL 10	LL	PN 100	4	M 10 x 1 K	8	16,0	20	11
XVM 05 LL	LL	PN 100	5	M 8 x 1 K	8	14,5	20	11
XVM 06 LL 6	LL	PN 100	6	M 6 x 1 K	8	14,5	20	11
XVM 06 LL 8	LL	PN 100	6	M 8 x 1 K	8	14,5	20	11
XVM 06 LL	LL	PN 100	6	M 10 x 1 K	8	14,5	20	11
XVM 08 LL	LL	PN 100	8	M 10 x 1 K	8	16,5	22	12
XVM 12 LL	LL	PN 100	12	M 16 x 1,5 K	12	21,0	27	19
XVMK NW 04 HL	L	PN 315	6	M 10 x 1 K	8	15,0	22	12
XVMK NW 06 HL	L	PN 315	8	M 12 x 1,5 K	12	20,0	27	14
XVMK NW 08 HL	L	PN 315	10	M 14 x 1,5 K	12	21,0	28	17
XVMK NW 10 HL	L	PN 315	12	M 16 x 1,5 K	12	22,0	29	19
XVMK NW 13 HL	L	PN 315	15	M 18 x 1,5 K	12	23,0	30	24
XVMK NW 16 HL	L	PN 315	18	M 22 x 1,5 K	14	25,5	33	27
XVMK NW 20 HL	L	PN 160	22	M 26 x 1,5 k	18	31,5	39	32
XVMK NW 25 HL	L	PN 160	28	M 33 x 2 K	20	34,5	42	41
XVMK NW 32 HL	L	PN 160	35	M 42 x 2 K	21	35,5	46	46
XVMK NW 40 HL	L	PN 160	42	M 48 x 2 K	22	38,0	49	55
XVMK NW 03 HS	S	PN 630	6	M 12 x 1,5 K	12	24,0	31	14

Serie: LL = zeer licht L = licht S = zwaar - PN = nominale druk PB = max. werkdruk - Ø d2 = buitendiameter buis

Productvarianten

XVMK VA	Inschroefverbinding, RVS
VMK	Inschroefverbinding, Staal