

# W90 HMOK L HJ

Inschroefsok, lang, bocht 90°

## Eigenschappen

<b>Aansluiting 1</b>	Metrische buitendraad cilindrisch
<b>Afdichtingsvorm 1</b>	O-ring afdichting op de inschroefsok
<b>Aansluiting 2</b>	UN/UNF-buitendraad
<b>Afdichtingsvorm 2</b>	74° buitenconus
<b>Constructie</b>	Inschroef-sok lang
<b>Uitvoering</b>	Bochtstuk 90°
<b>Materiaal</b>	Staal
<b>Oppervlakbescherming</b>	Galvanisch gecoat

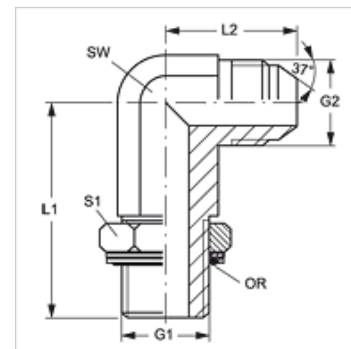

## Artikel

Aanduiding	G1	G2	L1 (mm)	L2 (mm)	SW (mm)	S1	OR
W90 HMOK L 10 HJ 05	M 10 x 1	1/2" -20 UNF	49,5	24,0	13	15	8,0 x 1,5
W90 HMOK L 12 HJ 05	M 12 x 1,5	1/2" -20 UNF	53,5	27,0	13	18	9,3 x 2,4
W90 HMOK L 14 HJ 06	M 14 x 1,5	9/16" -18 UNF	56,5	27,0	14	20	11,3 x 2,4
W90 HMOK L 16 HJ 06	M 16 x 1,5	9/16" -18 UNF	67,0	28,5	19	22	13,3 x 2,4
W90 HMOK L 18 HJ 08	M 18 x 1,5	3/4" -16 UNF	67,0	31,5	19	25	15,3 x 2,4
W90 HMOK L 18 HJ 10	M 18 x 1,5	7/8" -14 UNF	75,0	36,5	22	25	15,3 x 2,4
W90 HMOK L 20 HJ 10	M 20 x 1,5	7/8" -14 UNF	78,0	36,5	22	28	17,3 x 2,4
W90 HMOK L 22 HJ 10	M 22 x 1,5	7/8" -14 UNF	78,0	36,5	22	28	19,3 x 2,4

SW, S1, S2 = sleutelmaat

## Reserveonderdelen

**KAMMRING M** Kamerring, metrisch