

Eigenschappen

Aansluiting 1	Metrische moerdraad
Afdichtingsvorm 1	Buissok met snijring
Aansluiting 2	Metrische buitendraad cilindrisch
Afdichtingsvorm 2	24° binnenconus
Constructie	Koppeling richting instelbaar
Uitvoering	Bochtstuk 90°
Norm	DIN 2353 ISO 8434-1
Leveromvang	Buissok (zonder wartelmoer en snijring) voorgemonteerd
Materiaal	Staal
Oppervlakbescherming	Galvanisch gecoat

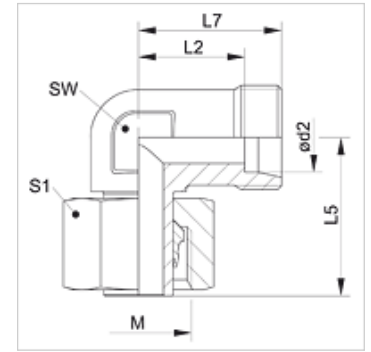

Aanwijzing

Aanwijzingen voor de montage, inbouw, drukbelasting en toegestane werktemperaturen staan in de technische informatie voor schroefdraadpijpvverbindingen.

Artikel

Aanduiding	Serie	Werkdruk bar	Ø d2 (mm)	M	L2 (mm)	L5 (mm)	L7 (mm)	SW (mm)	S1
XVEW NW 04 HL	L	PN 315	6	M 12 x 1,5	12,0	26,0	19	12	14
XVEW NW 06 HL	L	PN 315	8	M 14 x 1,5	14,0	27,5	21	12	17
XVEW NW 08 HL	L	PN 315	10	M 16 x 1,5	15,0	29,0	22	14	19
XVEW NW 10 HL	L	PN 315	12	M 18 x 1,5	17,0	29,5	24	17	22
XVEW NW 13 HL	L	PN 315	15	M 22 x 1,5	21,0	32,5	28	19	27
XVEW NW 16 HL	L	PN 315	18	M 26 x 1,5	23,5	35,5	31	24	32
XVEW NW 20 HL	L	PN 160	22	M 30 x 2	27,5	38,5	35	27	36
XVEW NW 25 HL	L	PN 160	28	M 36 x 2	30,5	41,5	38	36	41
XVEW NW 32 HL	L	PN 160	35	M 45 x 2	34,5	51,0	45	41	50
XVEW NW 40 HL	L	PN 160	42	M 52 x 2	40,0	56,0	51	50	60
XVEW NW 03 HS	S	PN 630	6	M 14 x 1,5	16,0	27,0	23	12	17
XVEW NW 04 HS	S	PN 630	8	M 16 x 1,5	17,0	27,5	24	14	19
XVEW NW 06 HS	S	PN 630	10	M 18 x 1,5	17,5	30,0	25	17	22
XVEW NW 08 HS	S	PN 630	12	M 20 x 1,5	21,5	31,0	29	17	24
XVEW NW 10 HS	S	PN 630	14	M 22 x 1,5	22,0	35,0	30	19	27
XVEW NW 13 HS	S	PN 400	16	M 24 x 1,5	24,5	36,5	33	24	30
XVEW NW 16 HS	S	PN 400	20	M 30 x 2	26,5	44,5	37	27	36
XVEW NW 20 HS	S	PN 400	25	M 36 x 2	30,0	50,0	42	36	46
XVEW NW 25 HS	S	PN 400	30	M 42 x 2	35,5	55,0	49	41	50
XVEW NW 32 HS	S	PN 315	38	M 52 x 2	41,0	63,0	57	50	60

Serie: LL = zeer licht L = licht S = zwaar – PN = nominale druk PB = max. werkdruk – Ø d2 = buitendiameter buis

Productvarianten

XVEW VA	Koppeling, bocht 90°, RVS
VEW	Koppeling, bocht 90°, Staal