

# TW-TG MG

Tankwagenarmatuur, messing

**HANSA FLEX**

## Eigenschappen

<b>Toepassingsgebied</b>	Tankwagen
<b>Aansluiting 1</b>	Slangaansluiting
<b>Aansluiting 2</b>	BSP-buitendraad cilindrisch
<b>Constructie</b>	met borgkraag
<b>Norm</b>	NEN EN 14 420-5
<b>Materiaal</b>	Messing

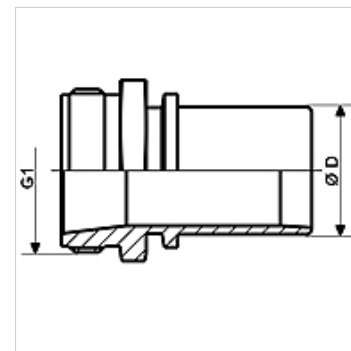

## Artikel

Aanduiding	DN*	Ø D (mm)	G1	Max. bedrijfsdruk (bar)
<b>TW-TG 12 13 MG</b>	13	13,4	G 1/2" -14	16
<b>TW-TG 34 19 MG</b>	19	19,4	G 3/4" -14	16
<b>TW-TG 10 19 MG</b>	19	19,4	G 1" -11	16
<b>TW-TG 10 25 MG</b>	25	25,4	G 1" -11	16
<b>TW-TG 114 32 MG</b>	31	32,4	G 1,1/4" -11	16
<b>TW-TG 112 35 MG</b>	35	35,0	G 1,1/2" -11	16
<b>TW-TG 112 38 MG</b>	38	38,4	G 1,1/2" -11	16
<b>TW-TG 20 38 MG</b>	38	38,4	G 2" -11	16
<b>TW-TG 20 50 MG</b>	50	50,4	G 2" -11	16
<b>TW-TG 212 63 MG</b>	63	63,4	G 2,1/2" -11	16
<b>TW-TG 30 75 MG</b>	75	75,4	G 3" -11	16
<b>TW-TG 30 80 MG</b>	80	80,4	G 3" -11	16
<b>TW-TG 40 100 MG</b>	100	100,4	G 4" -11	16

DN = nominale diameter, nominale wijdte

## Productvarianten

**TW-TG VA** Tankwagenarmatuur, RVS, RVS

## Toebehoren

<b>KS AL</b>	Klemdeel, aluminium
<b>KS FIX AL</b>	Klemschalen voor de borging met pennen, aluminium

## is toebehoren bij volgende producten

<b>TW</b>	Tankwagenslang
<b>TW OW</b>	Tankwagenslang zonder spiraalwinding