

TW-TG VA

Tankwagenarmatuur, RVS

HANSA FLEX

Eigenschappen

Toepassingsgebied	Tankwagen
Aansluiting 1	Slangaansluiting
Aansluiting 2	BSP-buitendraad cilindrisch
Constructie	met borgkraag
Norm	NEN EN 14 420-5
Materiaal	RVS

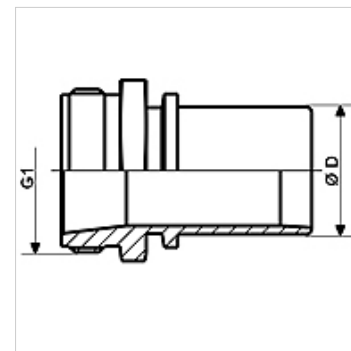

Artikel

Aanduiding	DN*	Ø D (mm)	G1	Max. bedrijfsdruk (bar)
TW-TG 12 13 VA	13	13,4	G 1/2" -14	16
TW-TG 34 19 VA	19	19,4	G 3/4" -14	16
TW-TG 10 25 VA	25	25,4	G 1" -11	16
TW-TG 114 32 VA	31	32,4	G 1,1/4" -11	16
TW-TG 112 38 VA	38	38,4	G 1,1/2" -11	16
TW-TG 20 50 VA	50	50,4	G 2" -11	16
TW-TG 212 63 VA	63	63,4	G 2,1/2" -11	16
TW-TG 30 63 VA	63	63,4	G 3" -11	16
TW-TG 30 75 VA	75	75,4	G 3" -11	16
TW-TG 30 80 VA	80	80,4	G 3" -11	16
TW-TG 40 100 VA	100	100,4	G 4" -11	16

DN = nominale diameter, nominale wijde

Productvarianten

TW-TG MG Tankwagenarmatuur, messing, Messing

Toebehoren

KS AL	Klemdeel, aluminium
KS FIX AL	Klemschalen voor de borging met pennen, aluminium

is toebehoren bij volgende producten

TW	Tankwagenslang
TW OW	Tankwagenslang zonder spiraalwinding