

K-DVST MIT REGLER

Pressure booster with regulator

HANSA FLEX

Eigenschappen

Ingangsdruk	2 - 10 bar
Uitgangsdruk	Max. 20 bar (regulated: max. 16 bar)
Temperatuurgebied	-10 °C to +50 °C (40 mm bore), -10 °C to +60 °C (63 mm bore)
Middelen	Filtered, unlubricated or lubricated compressed air (if lubrication is used, it must be continuous)
Afdichtmateriaal	NBR
Drukregelaar	With plastic body
Behuizing	Aluminium, anodised
Buis	Anodised aluminium jacket
Montage	Any position, with 4 mounting holes
P2:P1	1:1 to 1.6:1

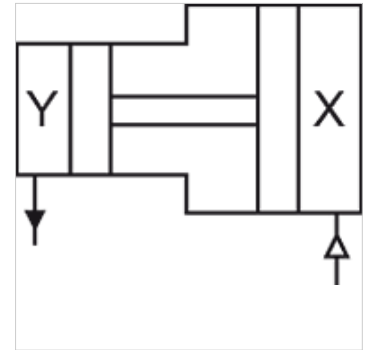
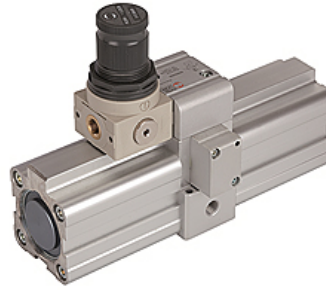

Aanwijzing

For information about calculating the filling times for different tank sizes, refer to the above-mentioned data sheet available on our website
Andere gegevens op aanvraag.

Beschrijving

Pressure multipliers (boosters) allow a separate compressed air store with up to double pressure to be installed for selected devices in a compressed air system without an external energy source, i.e. it is possible to work with a maximum pressure of 20 bar in a standard 10 bar system (maximum ratio 2:1). This is achieved using a double piston, which is operated by a combination of integrated check valves in such a way that the booster works automatically until the target pressure is reached in a compressed air tank and is then automatically switched off. A tank is always required to build up the pressure and store the compressed air!

Extra informatie

Fixing bracket with nut

Artikel

Aanduiding	Aansluiting	Ø zuiger (mm)	H (mm)	L (mm)
K- 07 25 08 65	G 1/8	40,0	139,0	194,0
K- 07 25 08 67	G 3/8	63,0	183,0	290,0

Toebehoren

K-ZUBEH ERSATZ LUFT BOOSTER Accessories / spare parts for Air-air-multiplier (booster)