

AFS G (3000 PSI)

Kołnierz wkręcany SAE, BSP

Właściwości

| | |
|---------------------|-------------------------|
| Szereg ciśnieniowy | 3000 psi |
| Norma | SAE J 518 C ISO 6162 |
| Kształt | prosty |
| Typ konstrukcji | kołnierz wkręcany SAE |
| Zamocowanie | otwór pod śrubę |
| Zakres dostawy | tylko kołnierz |
| Materiał | S355J2G3 (ST52.3) |
| Ochrona powierzchni | czarny olejowany |

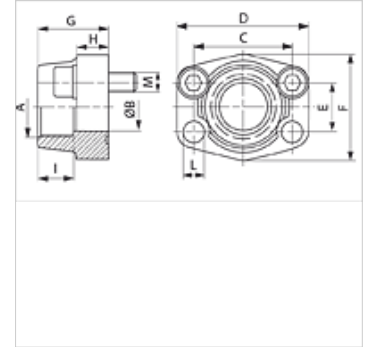

Wskazówka

Podane maksymalne ciśnienie robocze dotyczy kołnierza! Rzeczywiste ciśnienie robocze określa rura (grubość ścianki) oraz jakość rury!
Zalecane śruby są wymienione w kolumnach M (metr) lub M (unc).

Artykuł

| Oznaczenie | PB 10.9 (bar) | Typowielkość A | | Ø B (mm) | C (mm) | D (mm) | E (mm) | F (mm) | G (mm) | H (mm) | L (mm) | M metr. | M (unc) |
|--------------------|------------------|----------------|--------------|-------------|-----------|-----------|-----------|-----------|-----------|-----------|-----------|-----------|----------------|
| AFS 80 G 3/8 | 350 | 1/2" | G 3/8" -19 | 13 | 38,1 | 54 | 17,5 | 46 | 36 | 16 | 9,0 | M 8 x 30 | 5/16" x 1.1/4" |
| AFS 80 G 1/2 | 350 | 1/2" | G 1/2" -14 | 13 | 38,1 | 54 | 17,5 | 46 | 36 | 16 | 9,0 | M 8 x 30 | 5/16" x 1.1/4" |
| AFS 100 G 1/2 | 350 | 3/4" | G 1/2" -14 | 13 | 47,6 | 65 | 22,2 | 50 | 36 | 18 | 11,0 | M 10 x 35 | 3/8" x 1.1/2" |
| AFS 100 G 3/4 | 350 | 3/4" | G 3/4" -14 | 19 | 47,6 | 65 | 22,2 | 50 | 36 | 18 | 11,0 | M 10 x 35 | 3/8" x 1.1/2" |
| AFS 102 G 1/2 | 315 | 1" | G 1/2" -14 | 13 | 52,4 | 70 | 26,2 | 55 | 38 | 18 | 11,0 | M 10 x 35 | 3/8" x 1.1/2" |
| AFS 102 G 3/4 | 315 | 1" | G 3/4" -14 | 19 | 52,4 | 70 | 26,2 | 55 | 35 | 21 | 11,0 | M 10 x 35 | 3/8" x 1.1/2" |
| AFS 102 G 1 | 315 | 1" | G 1" -11 | 25 | 52,4 | 70 | 26,2 | 55 | 38 | 18 | 11,0 | M 10 x 35 | 3/8" x 1.1/2" |
| AFS 104 G 3/4 | 250 | 1.1/4" | G 3/4" -14 | 19 | 58,7 | 79 | 30,2 | 68 | 41 | 21 | 11,5 | M 10 x 40 | 7/16" x 1.1/2" |
| AFS 104 G 1 M10 | 250 | 1.1/4" | G 1" -11 | 25 | 58,7 | 81 | 30,2 | 65 | 42 | 25 | 11,5 | M 10 x 40 | - |
| AFS 104 G 1 M12 | 250 | 1.1/4" | G 1" -11 | 25 | 58,7 | 81 | 30,2 | 65 | 42 | 25 | 13,0 | M 12 x 40 | - |
| AFS 104 G1 1/4 M10 | 250 | 1.1/4" | G 1.1/4" -11 | 32 | 58,7 | 79 | 30,2 | 68 | 41 | 21 | 11,5 | M 10 x 40 | - |
| AFS 104 G1 1/4 M12 | 250 | 1.1/4" | G 1.1/4" -11 | 32 | 58,7 | 79 | 30,2 | 68 | 41 | 21 | 13,0 | M 12 x 40 | - |
| AFS 106 G 3/4 | 200 | 1.1/2" | G 3/4" -14 | 19 | 69,9 | 93 | 35,7 | 78 | 45 | 25 | 13,5 | M 12 x 45 | 1/2" x 1.3/4" |
| AFS 106 G 1 | 200 | 1.1/2" | G 1" -11 | 25 | 69,9 | 93 | 35,7 | 78 | 45 | 25 | 13,5 | M 12 x 45 | 1/2" x 1.3/4" |
| AFS 106 G 1 1/4 | 200 | 1.1/2" | G 1.1/4" -11 | 32 | 69,9 | 95 | 35,7 | 78 | 45 | 27 | 13,5 | M 12 x 45 | 1/2" x 1.3/4" |
| AFS 106 G 1 1/2 | 200 | 1.1/2" | G 1.1/2" -11 | 38 | 69,9 | 93 | 35,7 | 78 | 45 | 25 | 13,5 | M 12 x 45 | 1/2" x 1.3/4" |
| AFS 108 G 1 | 200 | 2" | G 1" -11 | 25 | 77,8 | 102 | 42,9 | 90 | 45 | 25 | 13,5 | M 12 x 45 | 1/2" x 1.3/4" |
| AFS 108 G 1 1/4 | 200 | 2" | G 1.1/4" -11 | 32 | 77,8 | 102 | 42,9 | 90 | 45 | 25 | 13,5 | M 12 x 45 | 1/2" x 1.3/4" |
| AFS 108 G 1 1/2 | 200 | 2" | G 1.1/2" -11 | 38 | 77,8 | 102 | 42,9 | 90 | 45 | 25 | 13,5 | M 12 x 45 | 1/2" x 1.3/4" |
| AFS 108 G 2 | 200 | 2" | G 2" -11 | 51 | 77,8 | 102 | 42,9 | 90 | 45 | 25 | 13,5 | M 12 x 45 | 1/2" x 1.3/4" |
| AFS 110 G 1 1/2 | 160 | 2.1/2" | G 1.1/2" -11 | 38 | 88,9 | 114 | 50,8 | 105 | 50 | 25 | 13,5 | M 12 x 45 | 1/2" x 1.3/4" |
| AFS 110 G 2 | 160 | 2.1/2" | G 2" -11 | 51 | 88,9 | 114 | 50,8 | 105 | 50 | 25 | 13,5 | M 12 x 45 | 1/2" x 1.3/4" |
| AFS 110 G 2 1/2 | 160 | 2.1/2" | G 2.1/2" -11 | 63 | 88,9 | 114 | 50,8 | 105 | 50 | 25 | 13,5 | M 12 x 45 | 1/2" x 1.3/4" |
| AFS 112 G 2 1/2 | 138 | 3" | G 2.1/2" -11 | 63 | 106,4 | 134 | 61,9 | 124 | 50 | 27 | 17,5 | M 16 x 50 | 5/8" x 2" |
| AFS 112 G 3 | 138 | 3" | G 3" -11 | 73 | 106,4 | 134 | 61,9 | 124 | 50 | 27 | 17,5 | M 16 x 50 | 5/8" x 2" |
| AFS 114 G 3 | 35 | 3.1/2" | G 3" -11 | 73 | 120,7 | 152 | 69,9 | 136 | 48 | 27 | 17,5 | M 16 x 50 | 5/8" x 2" |
| AFS 114 G 3 1/2 | 35 | 3.1/2" | G 3.1/2" -11 | 89 | 120,7 | 152 | 69,9 | 136 | 48 | 27 | 17,5 | M 16 x 50 | 5/8" x 2" |
| AFS 116 G 3 1/2 | 35 | 4" | G 3.1/2" -11 | 89 | 130,2 | 162 | 77,8 | 146 | 48 | 27 | 17,5 | M 16 x 50 | 5/8" x 2" |
| AFS 116 G 4 | 35 | 4" | G 4" -11 | 99 | 130,2 | 162 | 77,8 | 146 | 48 | 27 | 17,5 | M 16 x 50 | 5/8" x 2" |

PN = ciśnienie znamionowe PB = maks. ciśnienie robocze

Warianty produktu

| | |
|--------------------|---|
| AFS G M (3000 PSI) | Kołnierz wkręcany SAE, BSP, z zestawem śrub metrycznych i o-ringiem |
| AFS G U (3000 PSI) | Kołnierz wkręcany SAE, BSP, z zestawem śrub UNC i o-ringiem |