

HK CSTS N

głowica przegubowa z łożyskiem do smarowania uzupełniającego

HANSA FLEX

Właściwości

Norma DIN 648, SERIA E. TYP N

Zakres stosowania przemysł

Materiał stal ST 52.3

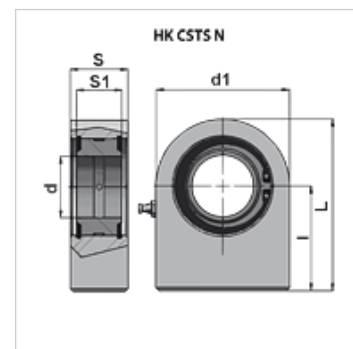
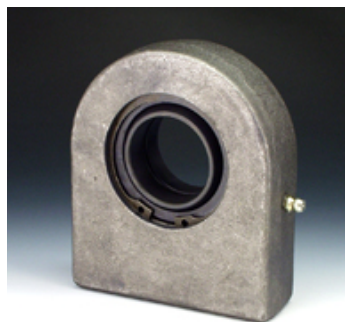

Wskazówka

dla HKCSTS09N00 nie ma możliwości uzupełniania smaru

Artykuł

Oznaczenie	d (mm)	d1 (mm)	l (mm)	L (mm)	S1 (mm)	S (mm)	dopuszczalne obciążenie dynamiczne (kN)	Ciężar (kg)
HK CSTS 016 N 00	16	48	35	59,0	14	18	21	0,29
HK CSTS 020 N 00	20	50	38	63,0	16	19	30	0,35
HK CSTS 025 N 00	25	55	45	72,5	20	23	48	0,53
HK CSTS 030 N 00	30	65	51	83,5	22	28	62	0,85
HK CSTS 035 N 00	35	83	61	102,5	25	30	80	1,50
HK CSTS 040 N 00	40	100	69	119,0	28	35	100	2,48
HK CSTS 045 N 00	45	110	77	132,0	32	40	127	3,45
HK CSTS 050 N 00	50	123	88	149,5	35	40	156	4,45
HK CSTS 060 N 00	60	140	100	170,0	44	50	245	7,10
HK CSTS 070 N 00	70	164	115	197,0	49	55	315	10,70
HK CSTS 080 N 00	80	180	141	231,0	55	60	400	15,10
HK CSTS 090 N 00	90	226	150	263,0	60	65	490	15,10