

K-PROP VENTIL LU GA 24 V DC

Proportional valves for controlling the flow of air / gas, 24 VDC, closed when de-energised

HANSA FLEX

Właściwości

Zakres temperatury	Max. 50 °C (G 1/8), Max. 90 °C (G 1/4, G 3/8)
Czynniki robocze	Air, neutral gases, water, oil
Zakres ciśnienia	Vacuum (max. 8 bar)
Wysterowanie	Via plug amplifier 0 to 10 V, 0 to 20 mA, 4 to 20 mA
zachowanie Failsafe	Tight closure in case of loss of voltage
obudowa, gniazdo zaworu	Brass
części wewnętrzne	Stainless steel
talerz zaworu	FKM
Materiał uszczelniający	FKM

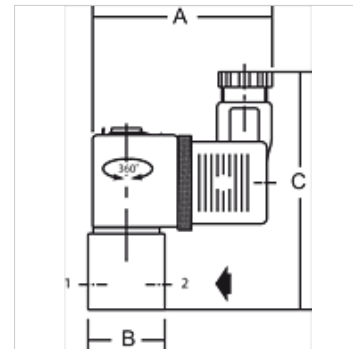

Wskazówka

Dalsze informacje na zapytanie.

Opis

Ever increasing requirements with regard to quality, precision, productivity, convenience, user friendliness and service represent tough challenges for industrial plant and production facilities. These challenges can only be mastered if physical quantities such as temperature, pressure, force, speed, torque, etc. are optimally adapted to the operating conditions of each installation. Stepless adjustment of these parameters is vital.

Proportional valves allow the medium to be varied as a function of an electronic input variable. By linking these valves to the electronics, it is possible to improve their accuracy and broaden their range of applications. A pressure regulator, for instance, needs to be suitable for several pressure ranges without having to adjust the pressure manually. Proportional valves control the output pressure in a closed control loop proportionally to the selected setpoint signal. This output pressure, in other words, is continually compared with the specified setpoint and automatically adjusted according to actual parameter values.

Dodatkowe informacje

We recommend combining these proportional valves with a plug amplifier, type K-07250999 or K-07251000

We recommend combining these proportional valves with a plug amplifier, type K-07250999 or K-07251000

Artykuł

Oznaczenie	Przyłącze	DN	maks. różnica ciśnienia roboczego (bar)	A (mm)	B	C (mm)
K- 07 25 09 91	G 1/4	2	8	85,0	40,0 mm	95,0
K- 07 25 09 92	G 1/4	3	4	85,0	40,0 mm	95,0
K- 07 25 09 93	G 3/8	6	1	85,0	48,0 mm	97,0
K- 07 25 09 94	G 3/8	7	1	85,0	48,0 mm	97,0