

G VKS ST 250

Flange quadrado Cetop, colar soldável

HANSA FLEX

Características

Tipo	Flange quadrado Cetop
Modelo	reto
Norma	CETOP RP 63H ISO 6164
Material	S355J2G3 (ST52.3)
Proteção de superfície	preto oleado

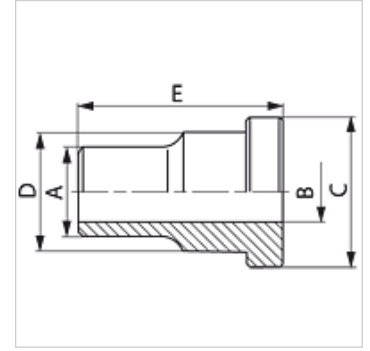

Artigo

Descrição	Pressão (PB) (bar)	Tamanho	A (mm)	Ø B (mm)	C (mm)	D (mm)	E (mm)
G VKS 38 ST 250	250	3/8"	18	12,5	24,5	18,0	30
G VKS 12 ST 250	250	1/2"	22	15,0	30,2	24,0	30
G VKS 34 ST 250	250	3/4"	28	20,0	38,1	31,5	35
G VKS 1 ST 250	250	1"	35	25,0	44,4	38,0	40
G VKS 114 ST 250	250	1.1/4"	43	32,0	50,8	43,0	45
G VKS 112 ST 250	250	1.1/2"	50	38,0	60,3	50,0	50
G VKS 2 ST 250	250	2"	62	47,0	71,4	62,0	60
G VKS 212 ST 250	250	2.1/2"	76	58,0	87,2	76,0	70
G VKS 3 ST 250	250	3"	90	70,0	101,6	90,0	80
G VKS 312 ST 250	250	3.1/2"	102	80,0	119,0	102,0	90
G VKS 4 ST 250	250	4"	114	90,0	131,0	114,0	105

PN = Pressão nominal PB = Pressão operacional máx. - Série: LL = muito leve L = leve S = pesada