

PHN 200

Capa para prensar para mangueira com trançado

HANSA FLEX

Características

Capa reusável	sem descasque (no skive)
apropriado para	1SN (HD 100) 2SN (HD 200) 2SC (KP 200)
Material	Aço
Proteção de superfície	com revestimento galvanizado

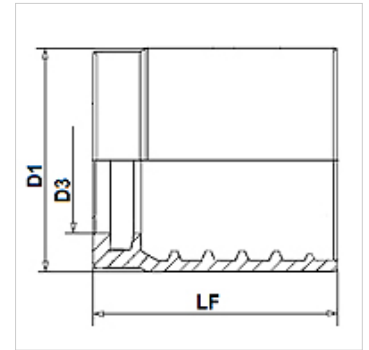

Nota

A atribuição do terminal depende do tipo de mangueira.

Artigo

Descrição	DN*	Tamanho	Polegada	D1 (mm)	D3 (mm)	LF (mm)
PHN 204	5	3	3/16"	21,0	9,5	23,5
PHN 206	6	4	1/4"	23,0	11,4	30,0
PHN 208	8	5	5/16"	24,0	13,2	30,0
PHN 210	10	6	3/8"	26,0	14,5	31,0
PHN 213	12	8	1/2"	29,0	18,3	32,0
PHN 216	16	10	5/8"	33,0	21,6	36,0
PHN 220	19	12	3/4"	37,0	24,4	42,5
PHN 225	25	16	1"	46,0	31,0	51,0
PHN 232	31	20	1.1/4"	59,0	38,3	57,5
PHN 240	38	24	1.1/2"	67,0	44,0	60,5
PHN 250	51	32	2"	80,0	57,0	74,0

DN = diâmetro nominal