

# SKF ORING

O-ring para SKF

**HANSA FLEX**

## Características

apropriado para Metade fixa do engate-rápido roscado

Material NBR

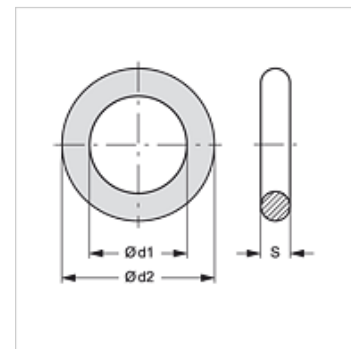

## Artigo

Descrição	Tamanho	Ø d1 (mm)	Ø d2 (mm)	S (mm)
SKF ORING 1	1	12,5	16,5	2,0
SKF ORING 2	2	17,0	21,0	2,0
SKF ORING 3	3	22,0	28,0	3,0
SKF ORING 4	4	28,0	34,0	3,0
SKF ORING 5	5	35,0	40,0	2,5
SKF ORING 6	6	54,0	60,0	3,0

## é peça sobressalente para os seguintes produtos

SKF HL / SKF HS	Metade fixa de engate-rápido roscado
SKFS HL / SKFS HS	Metade fixa de engate-rápido roscado
SKF IR	Metade fixa de engate-rápido roscado
SKF IM	Metade fixa de engate-rápido roscado
SKF HJ	Metade fixa de engate-rápido roscado
SKF SF6	Metade fixa de engate-rápido roscado