

PN SF 45

Terminal para prensar, SFL A45°

HANSA FLEX

Características

Campo de aplicação	Terminal para prensar para mangueiras HD 100 a HD 400, KP, TE
Conexão 1	Conexão de flange SAE para 3000 PSI
Tipo de vedação 1	vedação plana com O-ring SF
Abreviatura	SFL
Norma	SAE J518 ISO 6162-1
Material	Aço
Proteção de superfície	com revestimento galvanizado

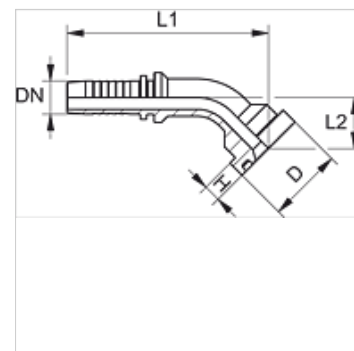

Nota

Selecione o terminal adequado de acordo com o tipo de mangueira.

Artigo

Descrição	DN	Tamanho	Polegada	Tamanho do flange	Pressão operacional (bar)	D (mm)	H (mm)	L1 (mm)	L2 (mm)
PN 13 SF 45	12	8	1/2"	1/2"	350,0	30,2	6,80	81,0	21,0
PN 13 SF 20 45	12	8	1/2"	3/4"	350,0	38,1	6,80	84,5	24,5
PN 16 SF 13 45	16	10	5/8"	1/2"	350,0	30,2	6,80	100,0	26,5
PN 16 SF 20 45	16	10	5/8"	3/4"	350,0	38,1	6,80	96,5	27,5
PN 20 SF 45	19	12	3/4"	3/4"	350,0	38,1	6,80	107,5	28,0
PN 20 SF 25 45	19	12	3/4"	1"	320,0	44,4	8,10	109,5	30,0
PN 25 SF 20 45	25	16	1"	3/4"	320,0	38,1	6,70	128,0	30,0
PN 25 SF 45	25	16	1"	1"	320,0	44,4	8,00	132,0	30,5
PN 25 SF 32 45	25	16	1"	1.1/4"	280,0	50,8	8,10	134,0	32,0
PN 32 SF 25 45	31	20	1.1/4"	1"	280,0	44,4	8,10	156,0	41,0
PN 32 SF 45	31	20	1.1/4"	1.1/4"	280,0	50,8	8,10	156,0	36,0
PN 32 SF 40 45	31	20	1.1/4"	1.1/2"	210,0	60,3	8,10	160,0	40,0
PN 40 SF 45	38	24	1.1/2"	1.1/2"	210,0	60,3	8,10	184,0	46,0
PN 40 SF 50 45	38	24	1.1/2"	2"	210,0	71,4	9,60	184,0	46,0
PN 50 SF 40 45	51	32	2"	1.1/2"	210,0	60,3	8,10	182,0	42,0
PN 50 SF 45	51	32	2"	2"	210,0	71,4	9,60	219,0	50,0
PN 50 SF 60 45	51	32	2"	2.1/2"	175,0	84,0	9,60	212,0	57,0
PN 60 SF 45	60	40	2.3/8"	2.1/2"	175,0	84,0	9,60	237,0	50,0
PN 60 SF 45 L 60	60	40	2.3/8"	2.1/2"	175,0	84,0	9,60	237,0	60,0
PN 76 SF 60 45	76	48	3"	2.1/2"	160,0	84,0	9,53	230,0	56,3
PN 76 SF 45	76	48	3"	3"	160,0	101,6	9,53	228,0	55,0

Variantes do produto

PN SF 45 VA Terminal para prensar, SFL A45°, Aço inoxidável