

SF O-RING V

O-ring, 90SH FKM (FPM)

Características

Tipo	Forma retangular
Temperatura min.	-15 °C
Temperatura max.	200 °C
Material	FKM SH 90 (Viton)

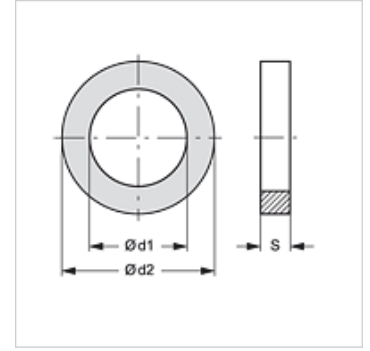

Artigo

Descrição	DN*	Tamanho	Polegada	Ø d1 (mm)	Ø d2 (mm)	S (mm)
SF ORING 13 V	12	8	1/2"	18,66	25,72	3,53
SF ORING 20 V	19	12	3/4"	24,99	32,05	3,53
SF ORING 25 V	25	16	1"	32,92	39,98	3,53
SF ORING 32 V	31	20	1.1/4"	37,70	44,76	3,53
SF ORING 40 V	38	24	1.1/2"	47,22	54,28	3,53
SF ORING 50 V	51	32	2"	56,74	63,80	3,53
SF ORING 60 V	60	40	2.1/2"	69,45	76,51	3,53
SF ORING 75 V	76	48	3"	85,32	92,38	3,53

Variantes do produto

SF O-RING PU