

O-Ringschnur 75° Shore FPM

Cordão de O-ring, 75SH FKM (FPM)

HANSA FLEX

Características

Tipo Cordão para O-ring

Cor preto

Temperatura min. -15 °C

Temperatura max. 200 °C

Material FPM 75 Shore

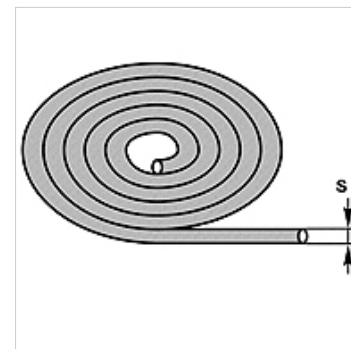

Artigo

Descrição	S (mm)	Tolerância
OR 178 FPM 75	1,78	+/- 0.20 mm
OR 240 FPM 75	2,40	+/- 0.20 mm
OR 250 FPM 75	2,50	+/- 0.20 mm
OR 300 FPM 75	3,00	+/- 0.25 mm
OR 400 FPM 75	4,00	+/- 0,30 mm
OR 450 FPM 75	4,50	+/- 0,30 mm
OR 500 FPM 75	5,00	+/- 0,30 mm
OR 534 FPM 75	5,34	+/- 0,30 mm
OR 570 FPM 75	5,70	+/- 0,30 mm
OR 600 FPM 75	6,00	+/- 0,30 mm
OR 700 FPM 75	7,00	+/- 0.40 mm
OR 800 FPM 75	8,00	+/- 0.40 mm
OR 900 FPM 75	9,00	+/- 0.40 mm