

AC OR AOL

O-ring para ar condicionado DKOL

HANSA FLEX

Características

Temperatura min. -40 °C

Temperatura max. 125 °C

Material NBR

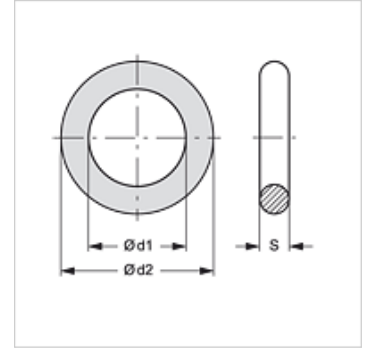

Artigo

Descrição	para mangueira DN	Ø d1 (mm)	Ø d2 (mm)	S (mm)
AC OR AOL 20	19	20	24	2,0
AC OR AOL 25	25	26	30	2,0
AC OR AOL 32	31	32	37	2,5