

K-SCHL-AUFROLLER LU WA L

Hose reels for compressed air and water, lightweight type

HANSA FLEX

Características

Material da mangueira	PVC
Pressão operacional	max. 12 bar (K-07100622); max. 20 bar (K-07100623)
Temperatura operacional	max. +60 °C
Bocal de entrada	G 1/4
Ângulo de rotação	180°

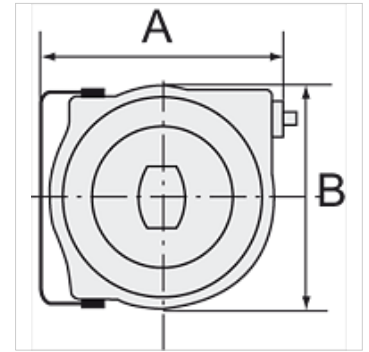

Nota

Outras indicações a pedido.

Descrição

High-quality, impact-resistant polypropylene housing. An automatic latching mechanism allows the hose to be engaged at any length. Enclosed spring. Precise locking device for continuous feeding or stop function. Reel guide prevents excessive wear on the hose.

Artigo

Descrição	Dimensão da mangueira	A (mm)	B (mm)	Comprimento da mangueira (m)
K- 07 10 06 22	12 mm x 8 mm	340,0	311,0	8
K- 07 10 06 23	12 mm x 6 mm	445,0	400,0	15