

K-SCHL-AUFROLLER WASSER

Hose reels for water

HANSA FLEX

Características

Material da mangueira	Braided PVC
Pressão operacional	Max. 9 bar
Temperatura operacional	+5 °C to +60 °C
Ângulo de rotação	300°

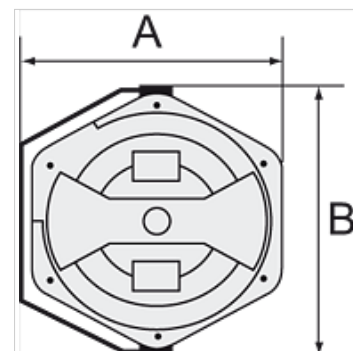

Nota

Outras indicações a pedido.

Descrição

For easy mounting on the wall or ceiling. Closed, rugged, impact-resistant housing made of POM, supply/outlet R 1/4 male thread and lightweight, hard-wearing, braided PVC hose. Incl. 2 m feeder hose.

Artigo

Descrição	Dimensão da mangueira	A (mm)	B (mm)	Comprimento da mangueira (m)
K- 07 10 06 17	13 mm x 9,5 mm	394,5	436,0	14