

### Características

Pressão operacional	Max. 40 bar
Rosca Descrição	With inside cone for ball-type hose fitting
Carcaça	Brass
Volante	Plastic
Fuso	With stainless steel ball

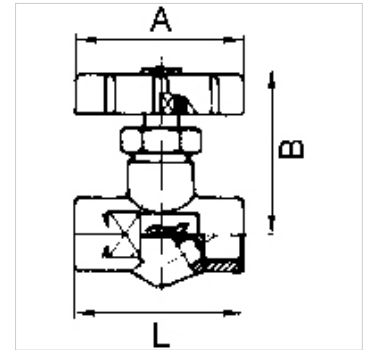
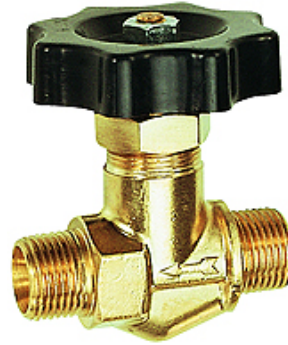

### Nota

Outras indicações a pedido.

### Artigo

Descrição	DN	Rosca	A (mm)	B (mm)	L (mm)	SW (mm)
K- 07 30 03 52	6	G 1/4	48,0	50,0	42,0	17
K- 07 30 03 53	8	G 3/8	48,0	55,0	52,0	22
K- 07 30 03 54	11	G 1/2	48,0	65,0	67,0	27