

K-SCHALLDAE SINTERBR IG

Silencers, sintered bronze, flat type with female thread

Características

Pressão operacional	máx. 10 bar
Temperatura operacional	-10 °C to +250 °C
Norma	Rosca BSP conforme DIN EN ISO 228-1

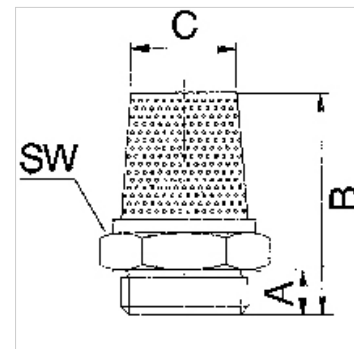

Nota

Outras indicações a pedido.

Descrição

For reducing the exhaust noise generated by pneumatic equipment.

Artigo

Descrição	Rosca	B (mm)	C (mm)	SW
K- 07 40 34 98	M 5	8,0	5,0	8 mm
K- 07 40 34 99	G 1/8	10,0	9,0	13 mm
K- 07 40 35 00	G 1/4	11,0	11,0	16 mm
K- 07 40 35 01	G 3/8	12,0	15,0	19 mm
K- 07 40 35 02	G 1/2	13,0	20,0	24 mm
K- 07 40 46 88	G 3/4	18,0	28,0	32 mm
K- 07 40 46 89	G 1	22,0	37,0	41 mm