

K-EINSCHRAUBVERTEILER

Male L-distributors

HANSA FLEX

Características

Pressão operacional máx. 10 bar

Material Latão

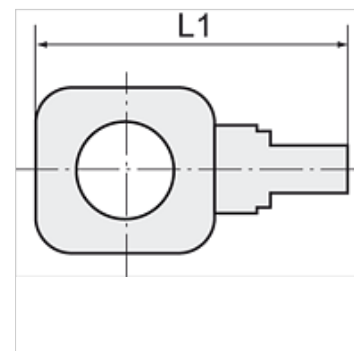
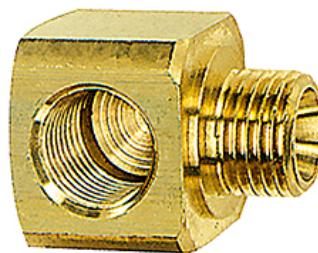

Nota

Outras indicações a pedido.

Artigo

| Descrição | Rosca | L1 (mm) | SW |
|----------------|-------|------------|-------|
| K- 07 40 14 63 | M 5 | 13,0 | 9 mm |
| K- 07 40 14 64 | G 1/8 | 23,0 | 17 mm |
| K- 07 40 14 65 | G 1/4 | 29,0 | 22 mm |
| K- 07 40 14 66 | G 3/8 | 32,0 | 27 mm |