

# K-ANFAV VARIOBLOC

Manifolds

**HANSA FLEX**

## Características

Pressão operacional 2 - 25 bar

Medição do valor de fluxo At P1 = 6 bar and pressure drop  $\Delta p = 1$  bar

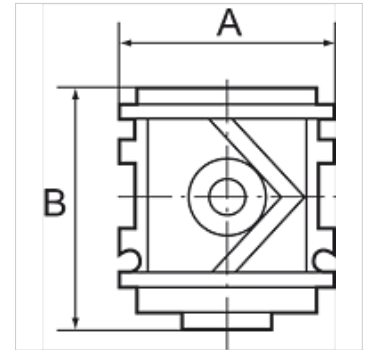
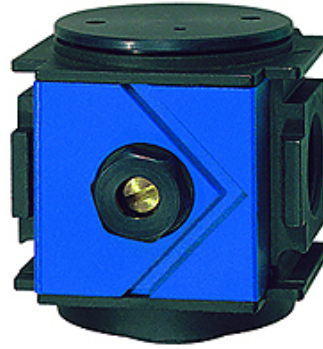

## Nota

Outras indicações a pedido.

## Descrição

For slow pressure build-up in pneumatic systems, e.g. after an emergency stop. The valve opens to full flow at approximately 60% of the set operating pressure. The filling time can be set by turning the adjusting screw. Used in combination with multi-piece service units.

## Artigo

Descrição	Rosca	Fluxo (L/min)	A (mm)	B	Pressão operacional bar
K- 07 25 11 84	G 1/4	1200	48,0	54,0 mm	2 - 25 bar
K- 07 25 11 85	G 3/8	1400	48,0	54,0 mm	2 - 25 bar
K- 07 25 11 86	G 1/2	3800	70,0	72,0 mm	2 - 25 bar
K- 07 25 11 87	G 3/4	4200	70,0	72,0 mm	2 - 25 bar
K- 07 25 11 88	G 1	4200	124,0	72,0 mm	2 - 25 bar