

K-VT 2-3 FACH MS BL

Distributors, 2 or 3 outlets, brass

HANSA FLEX

Características

Pressão operacional máx. 10 bar

Material Latão, superfície metálica

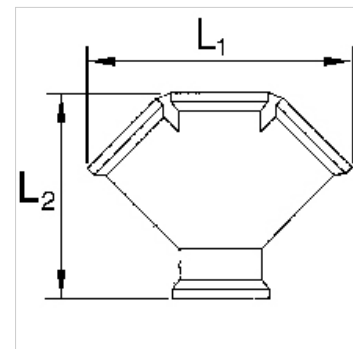

Nota

Outras indicações a pedido.

Artigo

Descrição	Rosca	Outlets	L1 (mm)	L2 (mm)
K- 07 40 40 16	G 3/8 female	2 x female	53,5	50,0
K- 07 40 40 17	G 1/2 female	2 x female	58,5	54,0
K- 07 40 40 18	G 3/8 female	3 x female	78,5	61,0
K- 07 40 40 19	G 1/2 female	3 x female	87,7	69,0