

# K-EINBAU-ROHRSTUECK 80-100 INFI

Mounting-pipe piece  $\varnothing$  80 mm/ $\varnothing$  110 mm with male thread to connect to the compressor

**HANSA FLEX**

## Características

**Material** Alumínio tratado superficialmente

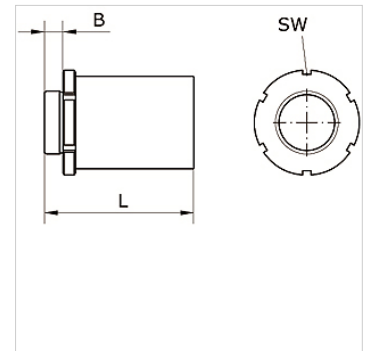

## Artigo

Descrição	$\varnothing$ externo do tubo	Conexão	B (mm)	L (mm)	SW (mm)
K- 07 40 55 13	80 mm	R 2 1/2	22,0	143,0	100
K- 07 40 54 63	110 mm	R 2 1/2	22,0	178,0	125
K- 07 40 54 64	110 mm	R 3	23,0	179,0	125