

K-KONSOLE STAHL VS INFI

Console made of steel galvanized

Características

Material Aço zincado

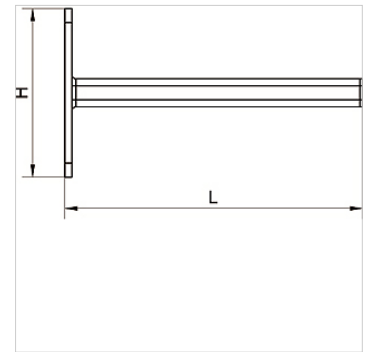

Artigo

Descrição	H (mm)	L (mm)	Comprimento (m)
K- 07 40 54 90	120,0	280,0	0,280