

K-KRONENBOHR SCHN-FLAN 20-63 INFI

Core drill for quick assembly \varnothing 20 mm – \varnothing 63 mm

HANSA FLEX

Características

Material Aço (HSS)

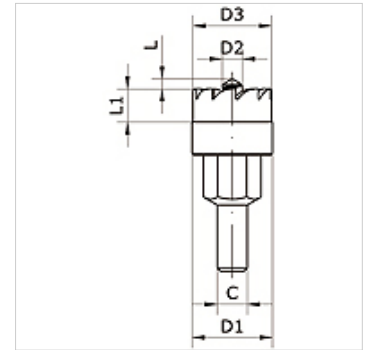
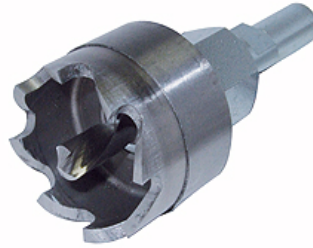

Artigo

Descrição	para \varnothing externo do tubo em mm	C (mm)	D1 (mm)	D2 (mm)	D3 (mm)	L (mm)	L1 (mm)
K- 07 40 54 52	32, 40	9,0	24,0	6	23,5	3,0	10,0
K- 07 40 54 53	50, 63	9,0	31,0	6	30,5	3,0	9,0