

K-RED FLANSCH 80-100 IG INFI

Reducing flange Ø 80 mm/Ø 110 mm with female thread

Características

Fluidos	Compressed air, vacuum, inert gases
Pressão operacional	-0,99 bar - 15 bar
Faixa de temperatura	-20 °C to +80 °C
Anel guia	Technopolymer
Carcaça	Aluminium, treated surface
Parafuso de sextavado interno	Galvanised steel
Anel de aperto	Stainless steel 1.4301
Porca	Aluminium, surface treated
O-Ring	NBR
Porca autotravante	Galvanised steel
Anel de fixação	Technopolymer

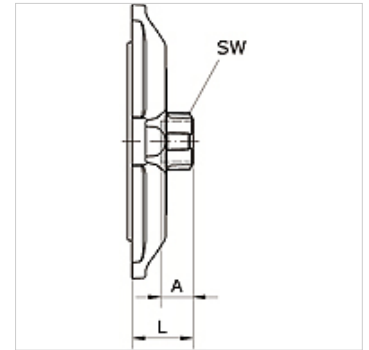

Artigo

Descrição	Conexão	para Ø externo do tubo em mm	A (mm)	L (mm)	SW (mm)
K- 07 40 55 23	G 3/4	80	14,5	42,0	42
K- 07 40 55 24	G 1	80	17,0	42,0	49
K- 07 40 55 25	G 1 1/2	80	20,0	42,0	66
K- 07 40 55 26	G 2	80	22,0	42,0	80
K- 07 40 54 73	G 3/4	110	14,5	48,0	42
K- 07 40 54 74	G 1	110	17,0	48,0	49
K- 07 40 54 75	G 1 1/2	110	20,0	48,0	66
K- 07 40 54 76	G 2	110	22,0	48,0	80