

# K-ROHRFLANSCH DICHT INFI

Seal for pipe flange

**HANSA FLEX**

## Características

**Material** NBR  
Fibra de carbono

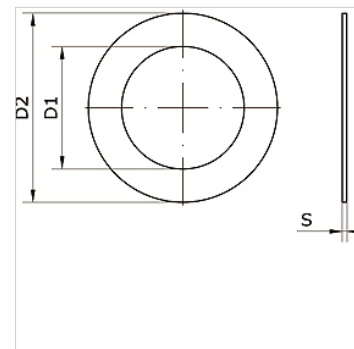

## Artigo

Descrição	para Ø externo do tubo em mm	D1 (mm)	D2 (mm)	S (mm)
K- 07 40 55 12	80	89,0	131	2
K- 07 40 54 59	110	105,0	162	2