

Caracteristici

Racord 1	Filete cilindrice interioare BSP
Formă de etanșare 1	Formă A
Racord 2	Filet metric exterior cilindric
Formă de etanșare 2	Con interior 24°
Tip constructiv	Racord filetat tip mamă
Forma constructivă	drept
Standard	DIN 2353 ISO 8434-1
Set de livrare	Ștuț cu piuliță olandeză și inel de tăiere
Material	Oțel
Protecția suprafeței	acoperire galvanică

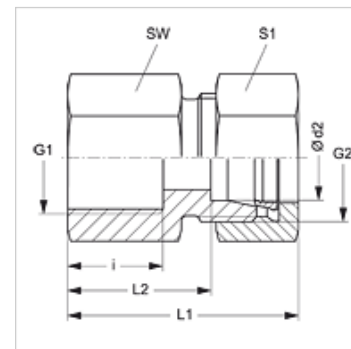

Indicație

Indicațiile privind montajul, asamblarea, încărcarea cu presiune și temperaturile de regim admisibile se găsesc în informațiile tehnice referitoare la îmbinările filetate pentru țevi.

Articol

Denumire	Seria	Presiune de lucru bar	Ø d2 (mm)	G1	G2	i (mm)	L1 (mm)	L2 (mm)	SW (mm)	S1
GAR NW 04 HL	L	PN 315	6	G 1/8" -28	M 12 x 1,5	12,0	34,0	19,0	14	14
GAR NW 04 HL 1/4	L	PN 315	6	G 1/4" -19	M 12 x 1,5	12,0	34,0	19,0	14	14
GAR NW 04 HL 3/8	L	PN 315	6	G 3/8" -19	M 12 x 1,5	12,0	36,0	21,0	22	14
GAR NW 06 HL	L	PN 315	8	G 1/4" -19	M 14 x 1,5	17,0	39,0	24,0	19	17
GAR NW 06 HL 3/8	L	PN 315	8	G 3/8" -19	M 14 x 1,5	17,0	36,0	21,0	22	17
GAR NW 06 HL 1/2	L	PN 315	8	G 1/2" -14	M 14 x 1,5	20,0	44,0	29,0	27	17
GAR NW 08 HL	L	PN 315	10	G 1/4" -19	M 16 x 1,5	17,0	40,0	25,0	19	19
GAR NW 08 HL 3/8	L	PN 315	10	G 3/8" -19	M 16 x 1,5	17,0	40,0	26,0	22	19
GAR NW 08 HL 1/2	L	PN 315	10	G 1/2" -14	M 16 x 1,5	20,0	45,0	30,0	27	19
GAR NW 10 HL 1/4	L	PN 315	12	G 1/4" -19	M 18 x 1,5	17,0	41,0	25,0	19	22
GAR NW 10 HL	L	PN 315	12	G 3/8" -19	M 18 x 1,5	17,0	41,0	26,0	22	22
GAR NW 10 HL 1/2	L	PN 315	12	G 1/2" -14	M 18 x 1,5	20,0	44,0	30,0	27	22
GAR NW 13 HL 3/8	L	PN 315	15	G 3/8" -19	M 22 x 1,5	17,0	46,0	27,0	24	27
GAR NW 13 HL	L	PN 315	15	G 1/2" -14	M 22 x 1,5	20,0	45,0	30,0	27	27
GAR NW 16 HL	L	PN 315	18	G 1/2" -14	M 26 x 1,5	20,0	46,0	29,5	27	32
GAR NW 20 HL	L	PN 160	22	G 3/4" -14	M 30 x 2	22,0	51,0	34,5	32	36
GAR NW 25 HL	L	PN 160	28	G 1" -11	M 36 x 2	24,5	53,5	37,0	41	41
GAR NW 32 HL	L	PN 160	35	G 1.1/4" -11	M 45 x 2	26,5	60,5	39,0	50	50
GAR NW 40 HL	L	PN 160	42	G 1.1/2" -11	M 52 x 2	28,5	63,5	40,5	55	60
GAR NW 03 HS	S	PN 400	6	G 1/4" -19	M 14 x 1,5	17,0	41,0	26,0	19	17
GAR NW 04 HS	S	PN 400	8	G 1/4" -19	M 16 x 1,5	17,0	41,0	26,0	19	19
GAR NW 06 HS	S	PN 400	10	G 3/8" -19	M 18 x 1,5	17,0	42,0	26,5	24	22
GAR NW 08 HS	S	PN 400	12	G 3/8" -19	M 20 x 1,5	17,0	42,0	26,5	24	24
GAR NW 10 HS	S	PN 400	14	G 1/2" -14	M 22 x 1,5	20,0	50,0	32,0	27	27
GAR NW 13 HS	S	PN 400	16	G 1/2" -14	M 24 x 1,5	20,0	50,0	31,5	27	30
GAR NW 16 HS	S	PN 315	20	G 3/4" -14	M 30 x 2	22,0	56,0	34,5	36	36
GAR NW 20 HS	S	PN 315	25	G 1" -11	M 36 x 2	24,5	61,5	37,5	41	46
GAR NW 25 HS	S	PN 315	30	G 1.1/4" -11	M 42 x 2	26,5	68,5	42,0	50	50
GAR NW 32 HS	S	PN 250	38	G 1.1/2" -11	M 52 x 2	28,5	74,5	43,5	60	60

Seria: LL = foarte ușoară L = ușoară S = grea - PN = Presiunea nominală PB = Presiunea max. de lucru - Ø d2 = diametru exterior țevă

Variante produs

GAR MG	Racord filetat tip mamă, Alamă
GAR VA	Racord filetat tip mamă, oțel inoxidabil
XGAR	Racord filetat tip mamă, Oțel