

Caracteristici

Racord 1	Filet metric exterior cilindric
Formă de etanșare 1	Con interior 24°
Racord 2	Filet metric exterior cilindric
Formă de etanșare 2	Con interior 24°
Tip constructiv	Îmbinare filetată
Forma constructivă	drept
Standard	ISO 8434-1
Set de livrare	Ștuț cu piuliță olandeză și inel de tăiere
Material	Oțel
Protecția suprafeței	acoperire galvanică

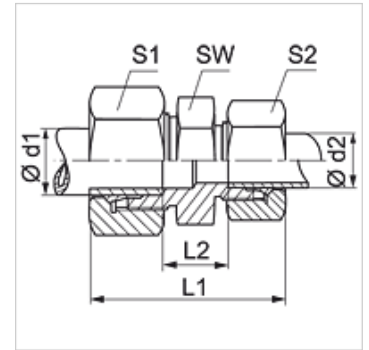

Indicație

Indicațiile privind montajul, asamblarea, încărcarea cu presiune și temperaturile de regim admisibile se găsesc în informațiile tehnice referitoare la îmbinările filetate pentru țevi.

Articol

Denumire	Seria	Presiune de lucru bar	Ø d1 (mm)	Ø d2 (mm)	L1 (mm)	L2 (mm)	SW (mm)	S1	S2
V 04 LL	LL	PN 100	4	4	31,0	12,0	9	10	10
V 05 LL	LL	PN 100	5	5	32,0	9,0	11	12	12
V 06 LL 04	LL	PN 100	6	4	32,0	10,5	11	12	10
V 06 LL	LL	PN 100	6	6	32,0	9,0	11	12	12
V 08 LL 04	LL	PN 100	8	4	34,0	12,5	12	14	10
V 08 LL 06	LL	PN 100	8	6	34,0	11,0	12	14	12
V 08 LL	LL	PN 100	8	8	35,0	12,0	12	14	14
V 10 LL	LL	PN 100	10	10	35,0	12,0	14	17	17
V 12 LL	LL	PN 100	12	12	35,0	11,0	17	19	19
V 16 LL	LL	PN 100	16	16	54,5	20,0	27	27	27
V NW 04 HL	L	PN 315	6	6	39,0	10,0	12	14	14
V NW 06 HL 04	L	PN 315	8	6	41,0	11,0	14	14	14
V NW 06 HL	L	PN 315	8	8	40,0	11,0	14	17	17
V NW 08 HL 04	L	PN 315	10	6	42,0	12,0	17	19	14
V NW 08 HL 06	L	PN 315	10	8	42,0	12,0	17	19	17
V NW 08 HL	L	PN 315	10	10	42,0	13,0	17	19	19
V NW 10 HL 04	L	PN 315	12	6	42,0	13,0	19	22	14
V NW 10 HL 06	L	PN 315	12	8	42,0	13,0	19	22	17
V NW 10 HL 08	L	PN 315	12	10	44,0	14,0	19	22	19
V NW 10 HL	L	PN 315	12	12	43,0	14,0	19	22	22
V NW 13 HL 04	L	PN 315	15	6	43,5	14,0	24	27	14
V NW 13 HL 06	L	PN 315	15	8	43,5	14,0	24	27	17
V NW 13 HL 08	L	PN 315	15	10	45,0	15,0	24	27	19
V NW 13 HL 10	L	PN 315	15	12	45,0	15,0	24	27	22
V NW 13 HL	L	PN 315	15	15	46,0	16,0	24	27	27
V NW 16 HL 04	L	PN 315	18	6	45,0	15,0	27	32	14
V NW 16 HL 06	L	PN 315	18	8	45,0	15,0	27	32	17
V NW 16 HL 08	L	PN 315	18	10	46,0	15,5	27	32	19
V NW 16 HL 10	L	PN 315	18	12	47,0	15,5	27	32	22
V NW 16 HL 10 27	L	PN 315	18	12	46,0	15,5	27	32	32
V NW 16 HL 13	L	PN 315	18	15	48,0	16,5	27	32	27
V NW 16 HL	L	PN 315	18	18	48,0	16,0	27	32	32
V NW 16 HL 27	L	PN 315	18	18	48,0	16,0	27	32	32
V NW 20 HL 06	L	PN 160	22	8	48,0	17,0	32	36	17
V NW 20 HL 08	L	PN 160	22	10	48,0	17,0	32	36	19
V NW 20 HL 10	L	PN 160	22	12	48,0	17,5	32	36	22
V NW 20 HL 13	L	PN 160	22	15	50,0	18,5	32	36	27
V NW 20 HL 16	L	PN 160	22	18	51,0	18,0	32	36	32
V NW 20 HL 16 27	L	PN 160	22	18	50,0	18,0	32	36	36
V NW 20 HL	L	PN 160	22	22	52,0	20,0	32	36	36
V NW 25 HL 06	L	PN 160	28	8	49,5	18,5	41	41	17
V NW 25 HL 08	L	PN 160	28	10	49,5	18,5	41	41	19



Articol

Denumire	Seria	Presiune de lucru bar	Ø d1 (mm)	Ø d2 (mm)	L1 (mm)	L2 (mm)	SW (mm)	S1	S2
V NW 25 HL 10	L	PN 160	28	12	51,0	19,0	41	41	22
V NW 25 HL 13	L	PN 160	28	15	51,0	19,5	41	41	27
V NW 25 HL 16	L	PN 160	28	18	52,0	19,0	41	41	32
V NW 25 HL 20	L	PN 160	28	22	54,0	21,0	41	41	36
V NW 25 HL	L	PN 160	28	28	54,0	21,0	41	41	41
V NW 32 HL 20	L	PN 160	35	22	59,0	21,0	46	50	36
V NW 32 HL 25	L	PN 160	35	28	59,0	21,0	46	50	41
V NW 32 HL	L	PN 160	35	35	63,0	20,0	46	50	50
V NW 40 HL 25	L	PN 160	42	28	62,0	22,5	65	60	41
V NW 40 HL 32	L	PN 160	42	35	66,0	21,5	55	60	50
V NW 40 HL	L	PN 160	42	42	66,0	21,0	55	60	60
V NW 16 HL 13 HS	L / S	PN 315	18	16	48,0	17,0	27	32	30
V NW 03 HS	S	PN 630	6	6	45,0	16,0	14	17	17
V NW 04 HS 03	S	PN 630	8	6	48,0	18,0	17	19	17
V NW 04 HS	S	PN 630	8	8	47,0	18,0	17	19	19
V NW 06 HS 03	S	PN 630	10	6	49,0	17,5	19	22	17
V NW 06 HS 04	S	PN 630	10	8	49,0	17,5	19	22	19
V NW 06 HS	S	PN 630	10	10	49,0	17,0	19	22	22
V NW 08 HS 03	S	PN 630	12	6	51,0	19,5	22	24	17
V NW 08 HS 04	S	PN 630	12	8	51,0	19,5	22	24	19
V NW 08 HS 06	S	PN 630	12	10	52,0	19,0	22	24	22
V NW 08 HS	S	PN 630	12	12	51,0	19,0	22	24	24
V NW 10 HS 03	S	PN 630	14	6	53,0	20,0	24	27	17
V NW 10 HS 04	S	PN 630	14	8	54,0	20,0	24	27	19
V NW 10 HS 06	S	PN 630	14	10	55,0	20,5	24	27	22
V NW 10 HS 08	S	PN 630	14	12	55,0	20,5	24	27	24
V NW 10 HS	S	PN 630	14	14	57,0	22,0	24	27	27
V NW 13 HS 03	S	PN 400	16	6	53,0	20,0	27	30	17
V NW 13 HS 04	S	PN 400	16	8	54,0	20,0	27	30	19
V NW 13 HS 06	S	PN 400	16	10	54,0	20,0	27	30	22
V NW 13 HS 08	S	PN 400	16	12	55,0	20,0	27	30	24
V NW 13 HS 10	S	PN 400	16	14	58,0	21,5	27	30	27
V NW 13 HS	S	PN 400	16	16	57,0	21,0	27	30	30
V NW 16 HS 06	S	PN 400	20	10	59,5	22,0	32	36	22
V NW 16 HS 08	S	PN 400	20	12	59,5	22,0	32	36	24
V NW 16 HS 10	S	PN 400	20	14	63,0	23,5	32	36	27
V NW 16 HS 13	S	PN 400	20	16	63,0	23,0	32	36	30
V NW 16 HS	S	PN 400	20	20	66,0	23,0	32	38	38
V NW 20 HS 13	S	PN 400	25	16	68,0	25,5	41	46	30
V NW 20 HS 16	S	PN 400	25	20	71,0	25,5	41	46	36
V NW 20 HS	S	PN 400	25	25	74,0	26,0	41	46	46
V NW 25 HS 13	S	PN 400	30	16	70,0	25,0	46	50	30
V NW 25 HS 16	S	PN 400	30	20	74,0	26,0	46	50	36
V NW 25 HS 20	S	PN 400	30	25	77,0	26,5	46	50	46
V NW 25 HS	S	PN 400	30	30	80,0	27,0	46	50	50
V NW 32 HS	S	PN 315	38	38	90,0	29,0	55	60	60
V NW 32 HS 13	S	PN 315	38	16	81,0	29,0	55	60	30
V NW 32 HS 20	S	PN 315	38	25	84,0	29,0	55	60	46
V NW 32 HS 25	S	PN 315	38	30	87,0	29,5	55	60	50
V NW 13 HS 13 HL	S / L	PN 400	16	15	60,0	22,0	27	30	27
V NW 16 HS 13 HL	S / L	PN 400	20	15	62,0	24,0	32	36	27
V NW 16 HS 16 HL	S / L	PN 400	20	18	62,0	24,0	32	36	32
V NW 20 HS 20 HL	S / L	PN 400	25	22	70,0	25,0	41	46	36

Seria: LL = foarte ușoară L = ușoară S = grea - PN = Presiunea nominală PB = Presiunea max. de lucru - Ø d1 = diametru exterior țevă - Ø d2 = diametru exterior țevă

Variante produs

V-LL MG / V-HL MG / V-HS MG	Îmbinare filetată, Alamă
V-LL VA / V-HL VA / V-HS VA	Îmbinare filetată, oțel inoxidabil
XV	Îmbinare filetată, Oțel