

Caracteristici

Racord 1	Filet metric exterior conic
Formă de etanșare 1	cu etanșare pe filet
Racord 2	Filet metric exterior cilindric
Formă de etanșare 2	Con interior 24°
Tip constructiv	Racord filetat tip tată
Forma constructivă	drept
Standard	DIN 2353 ISO 8434-1
Set de livrare	Ștuț cu piuliță olandeză și inel de tăiere
Material	Oțel
Protecția suprafeței	acoperire galvanică

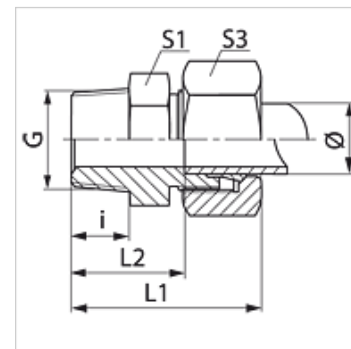

Indicație

Indicațiile privind montajul, asamblarea, încărcarea cu presiune și temperaturile de regim admisibile se găsesc în informațiile tehnice referitoare la îmbinările filetate pentru țevi.

Articol

Denumire	Seria	Presiune de lucru bar	Ø exterior țevă (mm)	G	i (mm)	L1 (mm)	L2 (mm)	S1	S3
VM 04 LL	LL	PN 100	4	M 8 x 1 K	8	26,0	16,0	11	10
VM 04 LL 10	LL	PN 100	4	M 10 x 1 K	8	26,0	16,0	11	10
VM 04 LL 6	LL	PN 100	4	M 6 x 1 K	8	27,0	16,0	10	10
VM 05 LL	LL	PN 100	5	M 8 x 1 K	8	26,0	14,5	11	12
VM 06 LL	LL	PN 100	6	M 10 x 1 K	8	26,0	14,5	11	12
VM 06 LL 6	LL	PN 100	6	M 6 x 1 K	8	27,5	14,5	11	12
VM 06 LL 8	LL	PN 100	6	M 8 x 1 K	8	26,0	14,5	11	12
VM 08 LL	LL	PN 100	8	M 10 x 1 K	8	28,0	16,5	12	14
VM 12 LL	LL	PN 100	12	M 16 x 1,5 K	12	32,0	20,0	17	19
VMK NW 04 HL	L	PN 315	6	M 10 x 1 K	10	23,0	17,0	12	14
VMK NW 06 HL	L	PN 315	8	M 12 x 1,5 K	12	25,0	20,0	17	17
VMK NW 08 HL	L	PN 315	10	M 14 x 1,5 K	12	26,0	21,0	17	19
VMK NW 10 HL	L	PN 315	12	M 16 x 1,5 K	12	27,0	22,0	19	22
VMK NW 13 HL	L	PN 315	15	M 18 x 1,5 K	12	29,0	23,0	24	27
VMK NW 16 HL	L	PN 315	18	M 22 x 1,5 K	14	31,0	25,5	27	32
VMK NW 20 HL	L	PN 160	22	M 26 x 1,5 k	18	33,0	31,5	32	36
VMK NW 25 HL	L	PN 160	28	M 33 x 2 K	20	34,0	34,5	41	41
VMK NW 32 HL	L	PN 160	35	M 42 x 2 K	21	39,0	35,5	46	50
VMK NW 40 HL	L	PN 160	42	M 48 x 2 K	22	42,0	38,0	55	60
VMK NW 03 HS	S	PN 630	6	M 12 x 1,5 K	12	40,0	24,0	17	17
VMK NW 04 HS	S	PN 630	8	M 14 x 1,5 K	12	42,0	25,0	17	19
VMK NW 06 HS	S	PN 630	10	M 16 x 1,5 K	12	43,0	24,5	19	22
VMK NW 08 HS	S	PN 630	12	M 18 x 1,5 K	12	45,0	26,5	22	24
VMK NW 10 HS	S	PN 630	14	M 20 x 1,5 K	14	51,0	30,0	24	27
VMK NW 13 HS	S	PN 400	16	M 22 x 1,5 K	14	51,0	31,5	27	30
VMK NW 16 HS	S	PN 400	20	M 27 x 2 K	18	60,0	35,5	32	36
VMK NW 20 HS	S	PN 400	25	M 33 x 2 K	20	67,0	38,0	41	46
VMK NW 25 HS	S	PN 400	30	M 42 x 2 K	21	71,0	40,5	56	50
VMK NW 32 HS	S	PN 315	38	M 48 x 2 K	22	79,0	44,0	55	60

Seria: LL = foarte ușoară L = ușoară S = grea - PN = Presiunea nominală PB = Presiunea max. de lucru - Ø = Diametrul exterior al țevii

Variante produs

VMK MG	Racord filetat tip tată, Alamă
VMK VA	Racord filetat tip tată, oțel inoxidabil
XVMK	Racord filetat tip tată, Oțel