

## Caracteristici

Racord 1	Filet metric exterior cilindric
Formă de etanșare 1	Formă F
Racord 2	Filet metric exterior cilindric
Formă de etanșare 2	Con interior 24°
Tip constructiv	Racord filetat tip tată
Forma constructivă	drept
Standard	ISO 8434-1
Set de livrare	Ștuț cu piuliță olandeză și inel de tăiere
Material	Oțel
Protecția suprafeței	acoperire galvanică

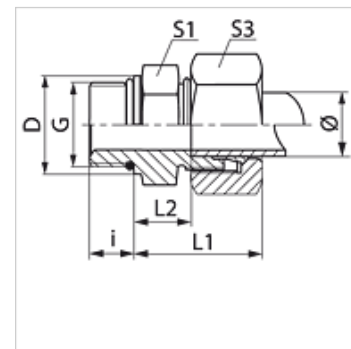

## Indicație

Indicațiile privind montajul, asamblarea, încărcarea cu presiune și temperaturile de regim admisibile se găsesc în informațiile tehnice referitoare la îmbinările filetate pentru țevi.

## Articol

Denumire	Seria	Presiune de lucru bar	Ø exterior țevă (mm)	G	D (mm)	i (mm)	L1 (mm)	L2 (mm)	S1	S3	Inel O
VMO 04 LL	LL	PN 100	4	M 8 x 1	10,8	6,5	19,0	9,5	11	10	6,1 x 1,6
VMO 04 LL 10	LL	PN 100	4	M 10 x 1	12,8	6,5	19,0	9,5	13	10	8,0 x 1,5
VMO 06 LL	LL	PN 100	6	M 10 x 1	12,8	6,5	19,5	8,0	13	12	8,0 x 1,5
VMO NW 04 HL	L	PN 250	6	M 10 x 1	14,0	8,0	23,0	8,5	14	14	8,0 x 1,5
VMO NW 06 HL	L	PN 250	8	M 12 x 1,5	17,0	12,0	25,0	10,0	17	17	9,3 x 2,4
VMO NW 08 HL	L	PN 250	10	M 14 x 1,5	19,0	12,0	26,0	11,0	19	19	11,3 x 2,4
VMO NW 10 HL	L	PN 250	12	M 16 x 1,5	22,0	12,0	27,0	12,5	22	22	13,3 x 2,4
VMO NW 13 HL	L	PN 250	15	M 18 x 1,5	24,0	12,0	29,0	13,5	24	27	15,3 x 2,4
VMO NW 16 HL	L	PN 160	18	M 22 x 1,5	27,0	14,0	32,0	14,5	27	32	19,3 x 2,4
VMO NW 20 HL	L	PN 160	22	M 26 x 1,5	31,0	16,0	34,0	16,5	32	36	23,3 x 2,4
VMO NW 20 HL 27	L	PN 160	22	M 27 x 2	32,0	16,0	33,0	16,5	32	36	23,6 x 2,9
VMO NW 25 HL	L	PN 100	28	M 33 x 2	41,0	18,0	34,0	17,5	41	41	29,5 x 3,0
VMO NW 32 HL	L	PN 100	35	M 42 x 2	50,0	20,0	39,0	17,5	50	50	38,0 x 3,0
VMO NW 40 HL	L	PN 160	42	M 48 x 2	55,0	17,5	42,0	19,0	55	60	44,60 x 3,00
VMO NW 03 HS	S	PN 630	6	M 12 x 1,5	17,0	12,0	28,0	13,0	17	17	9,3 x 2,4
VMO NW 04 HS	S	PN 630	8	M 14 x 1,5	19,0	12,0	30,0	15,0	19	19	11,3 x 2,4
VMO NW 06 HS	S	PN 630	10	M 16 x 1,5	22,0	12,0	31,0	15,0	22	22	13,3 x 2,4
VMO NW 08 HS	S	PN 630	12	M 18 x 1,5	24,0	12,0	33,0	17,0	24	24	15,3 x 2,4
VMO NW 13 HS	S	PN 400	16	M 22 x 1,5	27,0	14,0	37,0	18,5	27	30	19,3 x 2,4
VMO NW 16 HS	S	PN 400	20	M 27 x 2	32,0	16,0	41,0	20,5	32	36	23,5 x 3,0
VMO NW 20 HS	S	PN 400	25	M 33 x 2	41,0	18,0	47,0	23,0	41	46	29,5 x 3,0
VMO NW 25 HS	S	PN 250	30	M 42 x 2	50,0	20,0	50,0	23,5	50	50	38,0 x 3,0
VMO NW 32 HS	S	PN 315	38	M 48 x 2	55,0	21,5	57,0	26,0	55	60	44,6 x 2,9

Seria: LL = foarte ușoară L = ușoară S = grea - PN = Presiunea nominală PB = Presiunea max. de lucru - Ø = Diametrul exterior al țevii

## Variante produs

## XVMO