

Caracteristici

Racord 1	Filete NPT exterioare
Formă de etanșare 1	cu etanșare pe filet
Racord 2	Filet metric exterior cilindric
Formă de etanșare 2	Con interior 24°
Tip constructiv	Racord filetat tip tată
Forma constructivă	drept
Standard	DIN 2353 ISO 8434-1
Set de livrare	Ștuț cu piuliță olandeză și inel de tăiere
Material	Oțel
Protecția suprafeței	acoperire galvanică

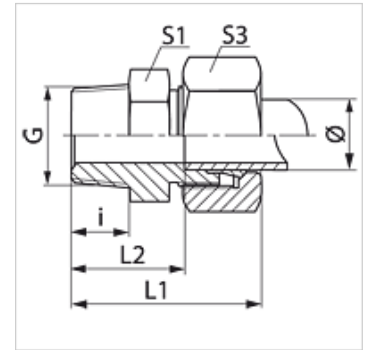

Indicație

Indicațiile privind montajul, asamblarea, încărcarea cu presiune și temperaturile de regim admisibile se găsesc în informațiile tehnice referitoare la îmbinările filetate pentru țevi.

Articol

Denumire	Seria	Presiune de lucru bar	Ø exterior țevă (mm)	G	i (mm)	L1 (mm)	L2 (mm)	S1	S3
VN 04 LL	LL	PN 100	4	1/8" -27 NPT	10,0	28,0	18,0	11	10
VN 05 LL	LL	PN 100	5	1/8" -27 NPT	10,0	28,0	16,5	11	12
VN 06 LL	LL	PN 100	6	1/8" -27 NPT	10,0	28,0	16,5	11	12
VN 08 LL	LL	PN 100	8	1/8" -27 NPT	10,0	30,0	18,5	12	14
VN NW 04 HL	L	PN 315	6	1/8" -27 NPT	10,0	32,0	17,0	12	14
VN NW 04 HL 1/4	L	PN 315	6	1/4" -18 NPT	15,0	38,0	23,0	17	14
VN NW 04 HL 3/8	L	PN 315	6	3/8" -18 NPT	15,0	39,0	24,0	19	14
VN NW 04 HL 1/2	L	PN 315	6	1/2" -14 NPT	20,0	44,0	29,0	24	14
VN NW 06 HL 1/8	L	PN 315	8	1/8" -27 NPT	10,0	38,0	23,0	12	17
VN NW 06 HL	L	PN 315	8	1/4" -18 NPT	15,0	38,0	23,0	17	17
VN NW 06 HL 3/8	L	PN 315	8	3/8" -18 NPT	15,5	39,0	24,0	19	17
VN NW 06 HL 1/2	L	PN 315	8	1/2" -14 NPT	20,0	44,0	29,0	24	17
VN NW 08 HL 1/8	L	PN 315	10	1/8" -27 NPT	15,5	39,5	25,0	17	19
VN NW 08 HL	L	PN 315	10	1/4" -18 NPT	15,0	39,0	24,0	17	19
VN NW 08 HL 3/8	L	PN 315	10	3/8" -18 NPT	15,2	40,0	25,0	19	19
VN NW 08 HL 1/2	L	PN 315	10	1/2" -14 NPT	20,0	45,0	30,0	24	19
VN NW 10 HL 1/8	L	PN 315	12	1/8" -27 NPT	15,0	40,0	25,0	19	22
VN NW 10 HL 1/4	L	PN 315	12	1/4" -18 NPT	15,0	40,0	25,0	19	22
VN NW 10 HL	L	PN 315	12	3/8" -18 NPT	15,5	40,0	25,0	19	22
VN NW 10 HL 1/2	L	PN 315	12	1/2" -14 NPT	20,0	45,0	30,0	24	22
VN NW 10 HL 3/4	L	PN 315	12	3/4" -14 NPT	20,0	45,0	32,0	27	22
VN NW 13 HL 1/4	L	PN 315	15	1/4" -18 NPT	15,0	40,0	25,0	24	22
VN NW 13 HL 3/8	L	PN 315	15	3/8" -18 NPT	15,5	41,5	26,5	24	27
VN NW 13 HL	L	PN 315	15	1/2" -14 NPT	20,0	46,0	31,0	24	27
VN NW 13 HL 3/4	L	PN 315	15	3/4" -14 NPT	20,0	46,0	32,0	27	27
VN NW 16 HL 1/4	L	PN 315	18	1/4" -18 NPT	15,0	32,0	25,0	27	32
VN NW 16 HL	L	PN 315	18	1/2" -14 NPT	20,0	48,0	31,5	27	32
VN NW 16 HL 3/4	L	PN 315	18	3/4" -14 NPT	20,0	48,5	32,0	27	32
VN NW 20 HL 1/2	L	PN 160	22	1/2" -14 NPT	20,0	50,0	33,5	32	36
VN NW 20 HL	L	PN 160	22	3/4" -14 NPT	20,0	50,0	33,5	32	36
VN NW 25 HL	L	PN 160	28	1" -11,5 NPT	25,0	56,0	39,5	41	41
VN NW 32 HL 1	L	PN 160	35	1" -11,5 NPT	25,0	62,0	40,5	46	50
VN NW 32 HL	L	PN 160	35	1.1/4" -11,5 NPT	25,5	62,0	40,5	46	50
VN NW 40 HL	L	PN 160	42	1.1/2" -11,5 NPT	26,0	65,0	42,0	55	60
VN NW 03 HS	S	PN 630	6	1/4" -18 NPT	15,0	43,0	28,0	17	17
VN NW 03 HS 1/2	S	PN 630	6	1/2" -14 NPT	20,0	50,0	35,0	24	17
VN NW 04 HS	S	PN 630	8	1/4" -18 NPT	15,0	43,0	28,0	17	19
VN NW 04 HS 3/8	S	PN 630	8	3/8" -18 NPT	15,5	43,0	28,0	19	19
VN NW 06 HS 1/4	S	PN 630	10	1/4" -18 NPT	15,0	44,0	27,5	19	22
VN NW 06 HS	S	PN 630	10	3/8" -18 NPT	15,5	44,0	27,5	19	22



Articol

Denumire	Seria	Presiune de lucru bar	Ø exterior țevă (mm)	G	i (mm)	L1 (mm)	L2 (mm)	S1	S3
VN NW 06 HS 1/2	S	PN 400	10	1/2" -14 NPT	20,0	51,0	34,5	24	22
VN NW 08 HS 1/4	S	PN 630	12	1/4" -18 NPT	15,1	46,0	29,5	22	24
VN NW 08 HS	S	PN 630	12	3/8" -18 NPT	15,5	46,0	29,5	22	24
VN NW 08 HS 1/2	S	PN 630	12	1/2" -14 NPT	20,0	51,0	34,5	24	24
VN NW 10 HS 3/8	S	PN 630	14	3/8" -18 NPT	15,5	54,0	36,0	24	27
VN NW 10 HS	S	PN 630	14	1/2" -14 NPT	20,0	54,0	36,0	24	27
VN NW 13 HS	S	PN 400	16	1/2" -14 NPT	20,0	54,0	35,5	27	30
VN NW 13 HS 3/4	S	PN 400	16	3/4" -14 NPT	20,0	56,0	37,5	32	30
VN NW 16 HS 1/2	S	PN 400	20	1/2" -14 NPT	20,0	59,0	37,5	32	30
VN NW 16 HS	S	PN 400	20	3/4" -14 NPT	20,0	59,0	37,5	32	36
VN NW 16 HS 1	S	PN 400	20	1" -11,5 NPT	25,0	66,0	44,5	41	36
VN NW 20 HS 3/4	S	PN 400	25	3/4" -14 NPT	20,0	64,0	40,0	41	46
VN NW 20 HS	S	PN 400	25	1" -11,5 NPT	25,0	69,0	45,0	41	46
VN NW 20 HS 1 1/4	S	PN 400	25	1.1/4" -11,5 NPT	25,5	69,0	45,5	46	46
VN NW 25 HS 1	S	PN 400	30	1" -11,5 NPT	25,0	66,5	40,0	46	50
VN NW 25 HS	S	PN 400	30	1.1/4" -11,5 NPT	25,5	73,0	46,5	46	50
VN NW 32 HS	S	PN 315	38	1.1/2" -11,5 NPT	26,0	80,0	49,0	55	60

Seria: LL = foarte ușoară L = ușoară S = grea - PN = Presiunea nominală PB = Presiunea max. de lucru - Ø = Diametrul exterior al țevii

Variante produs

VN MG	Racord filetat tip tată, Alamă
VN VA	Racord filetat tip tată, oțel inoxidabil
XVN	Racord filetat tip tată, Oțel