

Caracteristici

Racord 1	Filete cilindrice exterioare BSP
Formă de etanșare 1	Formă E
Racord 2	Filet metric exterior cilindric
Formă de etanșare 2	Con interior 24°
Tip constructiv	Racord filetat tip tată
Forma constructivă	drept
Standard	DIN 2353 ISO 8434-1
Set de livrare	Ștuț cu piuliță olandeză și inel de tăiere
Material	Oțel
Protecția suprafeței	acoperire galvanică

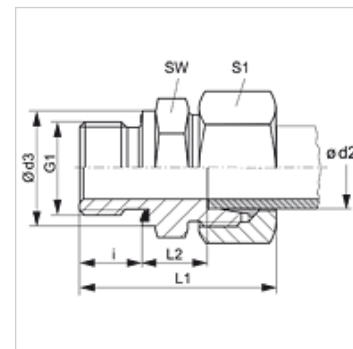

Indicație

Indicațiile privind montajul, asamblarea, încărcarea cu presiune și temperaturile de regim admisibile se găsesc în informațiile tehnice referitoare la îmbinările filetate pentru țevi.

Articol

Denumire	Seria	Presiune de lucru bar	Ø d2 (mm)	G1	Ø d3 (mm)	i (mm)	L1 (mm)	L2 (mm)	SW (mm)	S1
VR 04 LL ED	LL	PN 100	4	G 1/8" -28	14,0	8	28,0	9,5	14	10
VR 06 LL ED	LL	PN 100	6	G 1/8" -28	14,0	8	28,0	8,0	14	12
VR NW 04 HL ED	L	PN 315	6	G 1/8" -28	14,0	8	31,0	8,5	14	14
VR NW 04 HL 1/4 ED	L	PN 315	6	G 1/4" -19	18,7	12	39,0	10,0	19	14
VR NW 04 HL 1/2 ED	L	PN 315	6	G 1/2" -14	27,0	14	43,0	12,0	27	14
VR NW 04 HL 3/8 ED	L	PN 315	6	G 3/8" -19	22,0	12	39,0	11,5	22	14
VR NW 06 HL 1/8 ED	L	PN 315	8	G 1/8" -28	14,0	8	34,0	9,5	14	17
VR NW 06 HL ED	L	PN 315	8	G 1/4" -19	18,7	12	37,0	10,0	19	17
VR NW 06 HL 3/8 ED	L	PN 315	8	G 3/8" -19	22,0	12	40,5	11,5	22	17
VR NW 06 HL 1/2 ED	L	PN 315	8	G 1/2" -14	27,0	14	42,5	12,0	27	14
VR NW 08 HL 1/8 ED	L	PN 315	10	G 1/8" -28	14,0	8	35,5	10,5	17	19
VR NW 08 HL ED	L	PN 315	10	G 1/4" -19	18,7	12	38,0	11,0	19	19
VR NW 08 HL 3/8 ED	L	PN 315	10	G 3/8" -19	22,0	12	42,5	12,5	22	19
VR NW 08 HL 1/2 ED	L	PN 315	10	G 1/2" -14	26,7	14	46,5	13,0	27	19
VR NW 10 HL 1/4 ED	L	PN 315	12	G 1/4" -19	18,7	12	42,0	12,5	22	22
VR NW 10 HL ED	L	PN 315	12	G 3/8" -19	22,0	12	39,0	12,5	22	22
VR NW 10 HL 1/2 ED	L	PN 315	12	G 1/2" -14	26,7	14	45,0	13,0	27	22
VR NW 10 HL 3/4 ED	L	PN 160	12	G 3/4" -14	32,0	16	47,0	14,0	32	22
VR NW 13 HL 3/8 ED	L	PN 315	15	G 3/8" -19	22,0	12	43,0	13,6	27	27
VR NW 13 HL ED	L	PN 315	15	G 1/2" -14	26,7	14	43,0	14,0	27	27
VR NW 13 HL 3/4 ED	L	PN 315	15	G 3/4" -14	32,0	16	48,5	15,0	32	27
VR NW 16 HL 3/8 ED	L	PN 315	18	G 3/8" -19	22,0	12	45,0	14,0	27	32
VR NW 16 HL ED	L	PN 315	18	G 1/2" -14	26,7	14	45,0	14,5	27	32
VR NW 16 HL 3/4 ED	L	PN 315	18	G 3/4" -14	32,0	16	50,0	14,5	32	32
VR NW 20 HL 1/2 ED	L	PN 315	22	G 1/2" -14	27,0	14	51,0	16,5	32	36
VR NW 20 HL ED	L	PN 160	22	G 3/4" -14	32,0	16	49,0	16,5	32	36
VR NW 20 HL 1 ED	L	PN 160	22	G 1" -11	40,0	18	56,0	17,5	41	36
VR NW 25 HL 3/4 ED	L	PN 160	28	G 3/4" -14	32,0	16	54,0	17,5	41	41
VR NW 25 HL ED	L	PN 160	28	G 1" -11	39,7	18	52,0	17,5	41	41
VR NW 25 HL 1 1/4 ED	L	PN 160	28	G 1.1/4" -11	60,0	20	55,0	18,5	50	41
VR NW 32 HL 1 ED	L	PN 160	35	G 1" -11	40,0	18	60,0	17,5	46	50
VR NW 32 HL ED	L	PN 160	35	G 1.1/4" -11	49,7	20	59,0	17,5	50	50
VR NW 40 HL 1 1/4 ED	L	PN 160	42	G 1.1/4" -11	50,0	20	67,0	19,0	55	60
VR NW 40 HL ED	L	PN 160	42	G 1.1/2" -11	55,0	22	69,0	19,0	55	60
VR NW 03 HS ED	S	PN 630	6	G 1/4" -19	18,7	12	40,0	13,0	19	17
VR NW 03 HS 1/2 ED	S	PN 630	6	G 1/2" -14	27,0	14	48,0	18,0	27	17
VR NW 04 HS ED	S	PN 630	8	G 1/4" -19	18,7	12	42,0	15,0	19	19
VR NW 04 HS 3/8 ED	S	PN 630	8	G 3/8" -19	22,0	12	42,5	15,5	22	19
VR NW 06 HS 1/4 ED	S	PN 630	10	G 1/4" -19	18,7	12	42,5	14,5	22	22
VR NW 06 HS ED	S	PN 630	10	G 3/8" -19	22,0	12	43,0	15,0	22	22



Articol

Denumire	Seria	Presiune de lucru bar	Ø d2 (mm)	G1	Ø d3 (mm)	i (mm)	L1 (mm)	L2 (mm)	SW (mm)	S1
VR NW 06 HS 1/2 ED	S	PN 630	10	G 1/2" -14	26,7	14	47,0	17,5	27	22
VR NW 08 HS 1/4 ED	S	PN 630	12	G 1/4" -19	19,0	12	45,0	16,5	22	24
VR NW 08 HS ED	S	PN 630	12	G 3/8" -19	22,0	12	45,0	17,0	22	24
VR NW 08 HS 1/2 ED	S	PN 630	12	G 1/2" -14	27,0	14	47,5	17,5	27	24
VR NW 10 HS 3/8 ED	S	PN 630	14	G 3/8" -19	22,0	12	48,0	18,5	24	27
VR NW 10 HS ED	S	PN 630	14	G 1/2" -14	26,7	14	51,0	19,0	27	27
VR NW 10 HS 3/4 ED	S	PN 630	14	G 3/4" -14	32,0	16	55,0	21,0	32	27
VR NW 13 HS 3/8 ED	S	PN 400	16	G 3/8" -19	22,0	12	47,0	18,0	27	30
VR NW 13 HS ED	S	PN 400	16	G 1/2" -14	26,7	14	51,0	18,5	27	30
VR NW 13 HS 3/4 ED	S	PN 400	16	G 3/4" -14	32,0	16	55,0	20,5	32	30
VR NW 16 HS 1/2 ED	S	PN 400	20	G 1/2" -14	27,0	14	56,0	20,5	32	36
VR NW 16 HS ED	S	PN 400	20	G 3/4" -14	32,0	16	58,0	20,5	32	36
VR NW 16 HS 1 ED	S	PN 400	20	G 1" -11	39,7	18	62,0	20,5	41	36
VR NW 20 HS 1/2 ED	S	PN 400	25	G 1/2" -14	27,0	14	61,0	23,0	41	46
VR NW 20 HS 3/4 ED	S	PN 400	25	G 3/4" -14	32,0	16	63,0	23,0	41	46
VR NW 20 HS ED	S	PN 400	25	G 1" -11	39,7	18	65,0	23,0	41	46
VR NW 25 HS ED	S	PN 400	30	G 1.1/4" -11	49,7	20	70,0	23,5	50	50
VR NW 25 HS 1 ED	S	PN 400	30	G 1" -11	40,0	18	68,0	23,5	46	50
VR NW 32 HS 1 1/4 ED	S	PN 315	38	G 1.1/4" -11	50,0	20	74,0	26,0	55	60
VR NW 32 HS ED	S	PN 315	38	G 1.1/2" -11	55,0	22	79,0	26,0	55	60

Seria: LL = foarte ușoară L = ușoară S = grea - PN = Presiunea nominală PB = Presiunea max. de lucru - Ø d2 = diametru exterior țevă

Variante produs

VR ED MG Racord filetat tip tată, Alamă

VR ED VA Racord filetat tip tată, oțel inoxidabil

XVR ED Racord filetat tip tată, Oțel

Piese de schimb

WD Garnitură moale pentru racorduri filetate tip tată