

Caracteristici

Racord 1	Filete cilindrice interioare BSP
Formă de etanșare 1	Formă A
Racord 2	Filet metric exterior cilindric
Formă de etanșare 2	Con interior 24°
Tip constructiv	Racord filetat tip mamă
Forma constructivă	drept
Standard	DIN 2353 ISO 8434-1
Set de livrare	Ștuț (fără piuliță olandeză și inel de tăiere)
Material	Oțel
Protecția suprafeței	acoperire galvanică

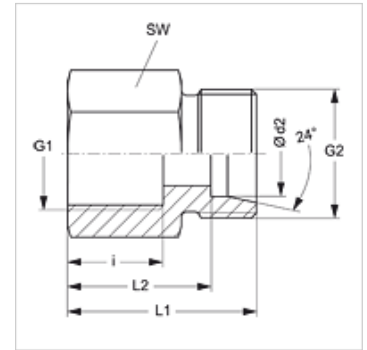

Indicație

Indicațiile privind montajul, asamblarea, încărcarea cu presiune și temperaturile de regim admisibile se găsesc în informațiile tehnice referitoare la îmbinările filetate pentru țevi.

Articol

Denumire	Seria	Presiune de lucru bar	Ø d2 (mm)	G1	G2	i (mm)	L1 (mm)	L2 (mm)	SW (mm)
XGAR NW 04 HL	L	PN 315	6	G 1/8" -28	M 12 x 1,5	12,0	26,0	19,0	14
XGAR NW 04 HL 1/4	L	PN 315	6	G 1/4" -19	M 12 x 1,5	17,0	31,0	24,0	19
XGAR NW 04 HL 3/8	L	PN 315	6	G 3/8" -19	M 12 x 1,5	17,0	32,0	25,0	22
XGAR NW 06 HL	L	PN 315	8	G 1/4" -19	M 14 x 1,5	17,0	31,0	24,0	19
XGAR NW 06 HL 3/8	L	PN 315	8	G 3/8" -19	M 14 x 1,5	17,0	32,0	25,0	22
XGAR NW 06 HL 1/2	L	PN 315	8	G 1/2" -14	M 14 x 1,5	20,0	36,0	29,0	27
XGAR NW 08 HL	L	PN 315	10	G 1/4" -19	M 16 x 1,5	17,0	32,0	25,0	19
XGAR NW 08 HL 3/8	L	PN 315	10	G 3/8" -19	M 16 x 1,5	17,0	33,0	26,0	22
XGAR NW 08 HL 1/2	L	PN 315	10	G 1/2" -14	M 16 x 1,5	20,0	37,0	30,0	27
XGAR NW 10 HL 1/4	L	PN 315	12	G 1/4" -19	M 18 x 1,5	17,0	32,0	25,0	19
XGAR NW 10 HL	L	PN 315	12	G 3/8" -19	M 18 x 1,5	17,0	33,0	26,0	22
XGAR NW 10 HL 1/2	L	PN 315	12	G 1/2" -14	M 18 x 1,5	20,0	37,0	30,0	27
XGAR NW 13 HL 3/8	L	PN 315	15	G 3/8" -19	M 22 x 1,5	17,0	34,0	27,0	24
XGAR NW 13 HL	L	PN 315	15	G 1/2" -14	M 22 x 1,5	20,0	38,0	31,0	27
XGAR NW 16 HL	L	PN 315	18	G 1/2" -14	M 26 x 1,5	20,0	38,0	30,5	27
XGAR NW 20 HL	L	PN 160	22	G 3/4" -14	M 30 x 2	22,0	43,0	35,5	32
XGAR NW 25 HL	L	PN 160	28	G 1" -11	M 36 x 2	24,5	45,5	38,0	41
XGAR NW 32 HL	L	PN 160	35	G 1.1/4" -11	M 45 x 2	26,5	51,5	41,0	50
XGAR NW 40 HL	L	PN 160	42	G 1.1/2" -11	M 52 x 2	28,5	53,5	42,5	55
XGAR NW 03 HS	S	PN 400	6	G 1/4" -19	M 14 x 1,5	17,0	33,0	26,0	19
XGAR NW 04 HS	S	PN 400	8	G 1/4" -19	M 16 x 1,5	17,0	33,0	26,0	19
XGAR NW 06 HS	S	PN 400	10	G 3/8" -19	M 18 x 1,5	17,0	34,0	26,5	24
XGAR NW 08 HS	S	PN 400	12	G 3/8" -19	M 20 x 1,5	17,0	34,0	26,5	24
XGAR NW 10 HS	S	PN 400	14	G 1/2" -14	M 22 x 1,5	20,0	40,0	32,0	27
XGAR NW 13 HS	S	PN 400	16	G 1/2" -14	M 24 x 1,5	20,0	40,0	31,5	27
XGAR NW 16 HS	S	PN 315	20	G 3/4" -14	M 30 x 2	22,0	45,0	34,5	36
XGAR NW 20 HS	S	PN 315	25	G 1" -11	M 36 x 2	24,5	49,5	37,5	41
XGAR NW 25 HS	S	PN 315	30	G 1.1/4" -11	M 42 x 2	26,5	55,5	42,0	50
XGAR NW 32 HS	S	PN 250	38	G 1.1/2" -11	M 52 x 2	28,5	59,5	43,5	60

Seria: LL = foarte ușoară L = ușoară S = grea - PN = Presiunea nominală PB = Presiunea max. de lucru - Ø d2 = diametru exterior țevă

Variante produs

XGAR VA	Racord filetat tip mamă, oțel inoxidabil
GAR	Racord filetat tip mamă, Oțel