

Caracteristici

Racord 1	Filet metric exterior cilindric
Formă de etanșare 1	Formă B
Racord 2	Filet metric exterior cilindric
Formă de etanșare 2	Con interior 24°
Tip constructiv	Racord filetat tip tată
Forma constructivă	drept
Standard	DIN 2353 ISO 8434-1
Set de livrare	Ștuț (fără piuliță olandeză și inel de tăiere)
Material	Oțel
Protecția suprafeței	acoperire galvanică

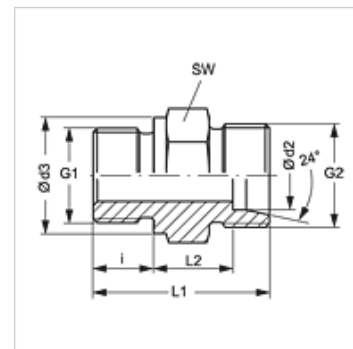

Indicație

Indicațiile privind montajul, asamblarea, încărcarea cu presiune și temperaturile de regim admisibile se găsesc în informațiile tehnice referitoare la îmbinările filetate pentru țevi.

Articol

Denumire	Seria	Presiune de lucru bar	Ø d2 (mm)	G1	G2	Ø d3 (mm)	i (mm)	L1 (mm)	L2 (mm)	SW (mm)
XVM 16 LL	LL	PN 100	16	M 22 x 1,5	M 22 x 1,5	27	14	36,5	15,5	27
XVM 16 LL 18-1.5	LL	PN 100	16	M 18 x 1,5	M 22 x 1,5	23	12	33,5	14,5	24
XVM NW 04 HL	L	PN 315	6	M 10 x 1	M 12 x 1,5	14	8	23,5	8,5	14
XVM NW 04 HL 12	L	PN 315	6	M 12 x 1,5	M 12 x 1,5	17	12	28,0	9,0	17
XVM NW 04 HL 14	L	PN 315	6	M 14 x 1,5	M 12 x 1,5	19	12	28,0	9,0	19
XVM NW 04 HL 16	L	PN 315	6	M 16 x 1,5	M 12 x 1,5	21	12	28,0	9,0	22
XVM NW 04 HL 18	L	PN 315	6	M 18 x 1,5	M 12 x 1,5	23	12	28,5	9,5	24
XVM NW 04 HL 22	L	PN 315	6	M 22 x 1,5	M 12 x 1,5	27	14	31,0	10,0	27
XVM NW 06 HL	L	PN 315	8	M 12 x 1,5	M 14 x 1,5	17	12	29,0	10,0	17
XVM NW 06 HL 10	L	PN 315	8	M 10 x 1	M 14 x 1,5	14	8	24,5	9,5	17
XVM NW 06 HL 14	L	PN 315	8	M 14 x 1,5	M 14 x 1,5	19	12	29,0	10,0	19
XVM NW 06 HL 16	L	PN 315	8	M 16 x 1,5	M 14 x 1,5	21	12	29,0	10,0	22
XVM NW 06 HL 18	L	PN 315	8	M 18 x 1,5	M 14 x 1,5	23	12	29,5	10,5	24
XVM NW 06 HL 22	L	PN 315	8	M 22 x 1,5	M 14 x 1,5	27	14	32,0	11,0	27
XVM NW 08 HL	L	PN 315	10	M 14 x 1,5	M 16 x 1,5	19	12	30,0	11,0	19
XVM NW 08 HL 12	L	PN 315	10	M 12 x 1,5	M 16 x 1,5	17	12	30,0	11,0	17
XVM NW 08 HL 16	L	PN 315	10	M 16 x 1,5	M 16 x 1,5	21	12	30,0	11,0	22
XVM NW 08 HL 18	L	PN 315	10	M 18 x 1,5	M 16 x 1,5	23	12	30,5	11,5	24
XVM NW 08 HL 22	L	PN 315	10	M 22 x 1,5	M 16 x 1,5	27	14	33,0	12,0	27
XVM NW 10 HL	L	PN 315	12	M 16 x 1,5	M 18 x 1,5	21	12	31,5	12,5	22
XVM NW 10 HL 12	L	PN 315	12	M 12 x 1,5	M 18 x 1,5	17	12	31,5	12,5	19
XVM NW 10 HL 14	L	PN 315	12	M 14 x 1,5	M 18 x 1,5	19	12	31,5	12,5	22
XVM NW 10 HL 18	L	PN 315	12	M 18 x 1,5	M 18 x 1,5	23	12	32,0	13,0	24
XVM NW 10 HL 22	L	PN 315	12	M 22 x 1,5	M 18 x 1,5	27	14	34,5	13,5	27
XVM NW 10 HL 24	L	PN 315	12	M 24 x 1,5	M 18 x 1,5	29	14	34,5	13,5	32
XVM NW 10 HL 26	L	PN 315	12	M 26 x 1,5	M 18 x 1,5	31	16	36,5	13,5	32
XVM NW 13 HL	L	PN 315	15	M 18 x 1,5	M 22 x 1,5	23	12	32,5	13,5	24
XVM NW 13 HL 14	L	PN 315	15	M 14 x 1,5	M 22 x 1,5	19	12	32,0	13,0	24
XVM NW 13 HL 16	L	PN 315	15	M 16 x 1,5	M 22 x 1,5	21	12	32,0	13,0	24
XVM NW 13 HL 20	L	PN 250	15	M 20 x 1,5	M 22 x 1,5	25	14	34,5	13,5	27
XVM NW 13 HL 22	L	PN 315	15	M 22 x 1,5	M 22 x 1,5	27	14	35,0	14,0	27
XVM NW 13 HL 26	L	PN 315	15	M 26 x 1,5	M 22 x 1,5	31	16	37,0	14,0	32
XVM NW 13 HL 30	L	PN 315	15	M 30 x 2	M 22 x 1,5	36	16	37,0	14,0	41
XVM NW 16 HL	L	PN 315	18	M 22 x 1,5	M 26 x 1,5	27	14	36,0	14,5	27
XVM NW 16 HL 18	L	PN 315	18	M 18 x 1,5	M 26 x 1,5	23	12	33,5	14,0	27
XVM NW 16 HL 26	L	PN 315	18	M 26 x 1,5	M 26 x 1,5	31	16	38,0	14,5	32
XVM NW 16 HL 27	L	PN 315	18	M 27 x 2	M 26 x 1,5	32	16	38,0	14,5	32
XVM NW 16 HL 30-1.5	L	PN 315	18	M 30 x 1,5	M 26 x 1,5	36	16	38,0	14,5	41
XVM NW 20 HL	L	PN 160	22	M 26 x 1,5	M 30 x 2	31	16	40,0	16,5	32
XVM NW 20 HL 18	L	PN 160	22	M 18 x 1,5	M 30 x 2	23	12	35,5	16,0	32
XVM NW 20 HL 22	L	PN 160	22	M 22 x 1,5	M 30 x 2	27	14	38,0	16,5	32



Articol

Denumire	Seria	Presiune de lucru bar	Ø d2 (mm)	G1	G2	Ø d3 (mm)	i (mm)	L1 (mm)	L2 (mm)	SW (mm)
XVM NW 20 HL 22-LS 20	L	PN 160	22	M 22 x 1,5	M 30 x 2	27	14	60,0	38,5	32
XVM NW 20 HL 30-1.5	L	PN 160	22	M 30 x 1,5	M 30 x 2	36	16	40,0	16,5	41
XVM NW 20 HL 33-LS 20	L	PN 160	22	M 33 x 2	M 30 x 2	39	18	62,0	36,5	41
XVM NW 25 HL	L	PN 160	28	M 33 x 2	M 36 x 2	39	18	43,0	17,5	41
XVM NW 25 HL-LS 20	L	PN 160	28	M 33 x 2	M 36 x 2	39	18	60,0	23,5	41
XVM NW 25 HL 22	L	PN 160	28	M 22 x 1,5	M 36 x 2	27	14	39,0	17,5	41
XVM NW 25 HL 26	L	PN 160	28	M 26 x 1,5	M 36 x 2	31	16	41,0	17,5	41
XVM NW 25 HL 27	L	PN 160	28	M 27 x 2	M 36 x 2	32	16	41,0	17,5	41
XVM NW 25 HL 42	L	PN 160	28	M 42 x 2	M 36 x 2	49	22	45,0	17,5	50
XVM NW 32 HL	L	PN 160	35	M 42 x 2	M 45 x 2	49	20	48,0	17,5	50
XVM NW 40 HL	L	PN 160	42	M 48 x 2	M 52 x 2	55	22	52,0	19,0	55
XVM NW 03 HS	S	PN 400	6	M 12 x 1,5	M 14 x 1,5	17	12	32,0	13,0	17
XVM NW 03 HS 16	S	PN 400	6	M 16 x 1,5	M 14 x 1,5	21	12	32,0	13,0	22
XVM NW 03 HS 18	S	PN 400	6	M 18 x 1,5	M 14 x 1,5	23	12	32,5	13,5	24
XVM NW 03 HS 22	S	PN 400	6	M 22 x 1,5	M 14 x 1,5	27	14	35,0	14,0	27
XVM NW 04 HS	S	PN 400	8	M 14 x 1,5	M 16 x 1,5	19	12	34,0	15,0	19
XVM NW 06 HS	S	PN 400	10	M 16 x 1,5	M 18 x 1,5	21	12	34,5	15,0	22
XVM NW 06 HS 18	S	PN 400	10	M 18 x 1,5	M 18 x 1,5	23	12	35,0	15,5	24
XVM NW 06 HS 22	S	PN 400	10	M 22 x 1,5	M 18 x 1,5	27	14	37,5	16,0	27
XVM NW 08 HS	S	PN 400	12	M 18 x 1,5	M 20 x 1,5	23	12	36,5	17,0	24
XVM NW 08 HS 14	S	PN 400	12	M 14 x 1,5	M 20 x 1,5	19	12	36,0	16,5	22
XVM NW 08 HS 16	S	PN 400	12	M 16 x 1,5	M 20 x 1,5	21	12	36,0	16,5	22
XVM NW 08 HS 22	S	PN 400	12	M 22 x 1,5	M 20 x 1,5	27	14	39,0	17,5	27
XVM NW 10 HS	S	PN 400	14	M 20 x 1,5	M 22 x 1,5	25	14	41,0	19,0	27
XVM NW 10 HS 16	S	PN 400	14	M 16 x 1,5	M 22 x 1,5	21	12	38,5	18,5	24
XVM NW 10 HS 18	S	PN 400	14	M 18 x 1,5	M 22 x 1,5	23	12	39,0	19,0	24
XVM NW 10 HS 22	S	PN 400	14	M 22 x 1,5	M 22 x 1,5	27	14	41,5	19,5	27
XVM NW 13 HS	S	PN 400	16	M 22 x 1,5	M 24 x 1,5	27	14	41,0	18,5	27
XVM NW 13 HS 16	S	PN 400	16	M 16 x 1,5	M 24 x 1,5	21	12	38,0	17,5	27
XVM NW 13 HS 18	S	PN 400	16	M 18 x 1,5	M 24 x 1,5	23	12	38,5	18,0	27
XVM NW 13 HS 26	S	PN 400	16	M 26 x 1,5	M 24 x 1,5	31	16	43,0	18,5	32
XVM NW 16 HS	S	PN 400	20	M 27 x 2	M 30 x 2	32	16	47,0	20,5	32
XVM NW 16 HS 22	S	PN 400	20	M 22 x 1,5	M 30 x 2	27	14	45,0	20,5	32
XVM NW 16 HS 26	S	PN 400	20	M 26 x 1,5	M 30 x 2	32	16	47,0	20,5	32
XVM NW 16 HS 30-1.5	S	PN 400	20	M 30 x 1,5	M 30 x 2	36	16	47,0	20,5	36
XVM NW 20 HS	S	PN 250	25	M 33 x 2	M 36 x 2	39	18	53,0	23,0	41
XVM NW 20 HS 26	S	PN 250	25	M 26 x 1,5	M 36 x 2	32	16	49,0	20,0	41
XVM NW 20 HS 27	S	PN 250	25	M 27 x 2	M 36 x 2	32	16	51,0	23,0	41
XVM NW 20 HS 30-1.5	S	PN 250	25	M 30 x 1,5	M 36 x 2	36	16	51,0	23,0	41
XVM NW 25 HS	S	PN 160	30	M 42 x 2	M 42 x 2	49	20	57,0	23,5	50
XVM NW 25 HS 30-1.5	S	PN 160	30	M 30 x 1,5	M 42 x 2	36	16	53,0	23,5	50
XVM NW 25 HS 38-1.5	S	PN 160	30	M 38 x 1,5	M 42 x 2	44	16	49,0	19,5	46
XVM NW 32 HS	S	PN 160	38	M 48 x 2	M 52 x 2	55	22	64,0	26,0	55
XVM NW 32 HS 38-1.5	S	PN 160	38	M 38 x 1,5	M 52 x 2	49	20	58,0	26,0	50
XVM NW 32 HS 45-1.5	S	PN 160	38	M 45 x 1,5	M 52 x 2	55	22	58,0	26,0	55

Seria: LL = foarte ușoară L = ușoară S = grea - PN = Presiunea nominală PB = Presiunea max. de lucru - Ø d2 = diametru exterior țevă

Variante produs

XVM VA	Racord filetat tip tată, oțel inoxidabil
VM	Racord filetat tip tată, Oțel