

XVU VA

Racord filetat tip tată

Caracteristici

Racord 1	Filete UN/UNF exterioare
Formă de etanșare 1	Formă F
Racord 2	Filet metric exterior cilindric
Formă de etanșare 2	Con interior 24°
Tip constructiv	Racord filetat tip tată
Forma constructivă	drept
Standard	DIN 2353 ISO 8434-1
Set de livrare	Ștuț (fără piuliță olandeză și inel de tăiere)
Material	oțel inoxidabil

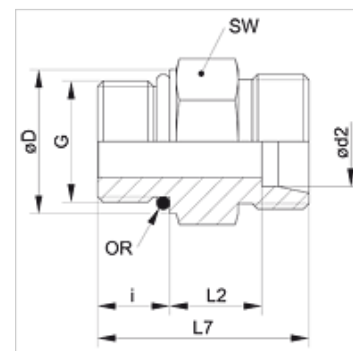

Indicație

Indicațiile privind montajul, asamblarea, încărcarea cu presiune și temperaturile de regim admisibile se găsesc în informațiile tehnice referitoare la îmbinările filetate pentru țevi.

Articol

Denumire	Seria	Presiune de lucru bar	Ø d2 (mm)	G	Ø D (mm)	i (mm)	L2 (mm)	L7 (mm)	SW (mm)	Inel O
XVU NW 04 HL 9/16 VA	L	PN 315	6	9/16" -18 UNF	17,6	10,0	11,0	28,0	19	11,89 x 1,98
XVU NW 04 HL 7/16 VA	L	PN 315	6	7/16" -20 UNF	14,4	9,1	9,9	26,0	17	9,17 x 1,83
XVU NW 04 HL 1/2 VA	L	PN 315	6	1/2" -20 UNF	16,8	9,1	9,9	26,0	17	10,52 x 1,83
XVU NW 06 HL 7/16 VA	L	PN 315	8	7/16" -20 UNF	14,4	9,1	12,9	29,0	17	9,17 x 1,83
XVU NW 06 HL 1/2 VA	L	PN 315	8	1/2" -20 UNF	16,8	9,1	12,9	29,0	17	10,52 x 1,83
XVU NW 06 HL 9/16 VA	L	PN 315	8	9/16" -18 UNF	17,6	10,0	13,0	30,0	19	11,89 x 1,98
XVU NW 08 HL 7/16 VA	L	PN 315	10	7/16" -20 UNF	14,4	9,1	13,9	30,0	17	9,17 x 1,83
XVU NW 08 HL 1/2 VA	L	PN 315	10	1/2" -20 UNF	17,0	9,2	11,0	26,0	17	10,52 x 1,83
XVU NW 08 HL 9/16 VA	L	PN 315	10	9/16" -18 UNF	17,6	10,0	14,0	31,0	19	11,89 x 1,98
XVU NW 08 HL 3/4 VA	L	PN 315	10	3/4" -16 UNF	22,3	11,1	14,9	33,0	24	16,36 x 2,20
XVU NW 10 HL 9/16 VA	L	PN 315	12	9/16" -18 UNF	17,6	10,0	12,0	29,0	19	11,89 x 1,98
XVU NW 10 HL 3/4 VA	L	PN 315	12	3/4" -16 UNF	22,3	11,1	12,9	31,0	24	16,36 x 2,20
XVU NW 10 HL 7/8 VA	L	PN 315	12	7/8" -14 UNF	25,5	12,7	14,3	34,0	27	19,18 x 2,46
XVU NW 13 HL 9/16 VA	L	PN 315	15	9/16" -18 UNF	17,6	10,0	14,0	31,0	24	11,89 x 1,98
XVU NW 13 HL 3/4 VA	L	PN 315	15	3/4" -16 UNF	22,3	11,1	13,9	32,0	24	16,36 x 2,20
XVU NW 13 HL 7/8 VA	L	PN 315	15	7/8" -14 UNF	25,5	12,7	15,8	35,5	27	19,18 x 2,46
XVU NW 16 HL 3/4 VA	L	PN 315	18	3/4" -16 UNF	22,3	11,1	14,4	33,0	27	16,36 x 2,20
XVU NW 16 HL 7/8 VA	L	PN 315	18	7/8" -14 UNF	25,5	12,7	14,5	34,7	27	19,18 x 2,46
XVU NW 16 HL 1 1/16 VA	L	PN 315	18	1.1/16" -12 UN	31,9	15,1	14,4	37,0	32	23,47 x 2,95
XVU NW 20 HL 7/8 VA	L	PN 160	22	7/8" -14 UNF	25,5	12,7	16,8	37,0	32	19,18 x 2,46
XVU NW 20 HL 1 1/16 VA	L	PN 160	22	1.1/16" -12 UN	31,9	15,1	16,4	39,0	32	23,47 x 2,95
XVU NW 20 HL 1 5/16 VA	L	PN 160	22	1.5/16" -12 UN	38,2	15,1	17,4	40,0	41	29,74 x 2,95
XVU NW 25 HL 1 1/16 VA	L	PN 160	28	1.1/16" -12 UN	31,9	15,1	17,4	40,0	41	23,47 x 2,95
XVU NW 25 HL 1 5/16 VA	L	PN 160	28	1.5/16" -12 UN	38,2	15,1	17,4	40,0	41	29,74 x 2,95
XVU NW 32 HL 1 5/8 VA	L	PN 160	35	1.5/8" -12 UN	47,7	15,1	17,4	43,0	50	37,47 x 3,00
XVU NW 03 HS 7/16 VA	S	PN 630	6	7/16" -20 UNF	14,4	9,1	14,9	31,0	17	9,17 x 1,83
XVU NW 04 HS 7/16 VA	S	PN 630	8	7/16" -20 UNF	14,4	9,1	14,9	31,0	17	9,17 x 1,83
XVU NW 04 HS 1/2 VA	S	PN 630	8	1/2" -20 UNF	16,8	9,1	14,9	31,0	19	10,52 x 1,83
XVU NW 04 HS 9/16 VA	S	PN 630	8	9/16" -18 UNF	17,6	10,0	15,0	32,0	19	11,89 x 1,98
XVU NW 06 HS 9/16 VA	S	PN 630	10	9/16" -18 UNF	17,6	10,0	14,5	32,0	19	10,89 x 1,98
XVU NW 06 HS 3/4 VA	S	PN 630	10	3/4" -16 UNF	22,3	11,1	14,4	33,0	24	16,36 x 2,20
XVU NW 08 HS 9/16 VA	S	PN 630	12	9/16" -18 UNF	17,6	10,0	14,5	32,0	22	11,89 x 1,98
XVU NW 08 HS 3/4 VA	S	PN 630	12	3/4" -16 UNF	22,3	11,1	17,4	36,0	24	16,36 x 2,20
XVU NW 08 HS 7/8 VA	S	PN 630	12	7/8" -14 UNF	25,5	12,7	17,8	38,0	27	19,18 x 2,46
XVU NW 13 HS 3/4 VA	S	PN 400	16	3/4" -16 UNF	22,3	11,1	15,4	35,0	24	16,36 x 2,20
XVU NW 13 HS 7/8 VA	S	PN 400	16	7/8" -14 UNF	25,5	12,7	18,8	40,0	27	19,18 x 2,46
XVU NW 16 HS 3/4 VA	S	PN 400	20	3/4" -16 UNF	22,3	11,1	20,4	42,0	32	16,36 x 2,20
XVU NW 16 HS 7/8 VA	S	PN 400	20	7/8" -14 UNF	25,5	12,7	20,8	44,0	32	19,18 x 2,46
XVU NW 16 HS 1 1/16 VA	S	PN 400	20	1.1/16" -12 UN	31,9	15,1	20,4	46,0	32	23,47 x 2,95
XVU NW 20 HS 1 1/16 VA	S	PN 400	25	1.1/16" -12 UN	31,9	15,1	22,9	50,0	41	23,47 x 2,95
XVU NW 20 HS 1 5/16 VA	S	PN 400	25	1.5/16" -12 UN	38,2	15,1	22,9	50,0	41	29,74 x 2,95
XVU NW 25 HS 1 5/16 VA	S	PN 400	30	1.5/16" -12 UN	38,2	15,1	23,4	52,0	46	29,74 x 2,95
XVU NW 25 HS 1 5/8 VA	S	PN 400	30	1.5/8" -12 UN	47,7	15,1	23,4	52,0	50	37,47 x 3,00



Articol

Denumire	Seria	Presiune de lucru bar	Ø d2 (mm)	G	Ø D (mm)	i (mm)	L2 (mm)	L7 (mm)	SW (mm)	Inel O
XVU NW 32 HS 1 5/8 VA	S	PN 315	38	1.5/8" -12 UN	47,7	15,1	25,9	57,0	55	37,47 x 3,00
XVU NW 32 HS 17/8 VA	S	PN 315	38	1.7/8" -12 UN	53,8	15,1	25,9	57,0	60	43,69 x 3,00

Seria: LL = foarte ușoară L = ușoară S = grea - PN = Presiunea nominală PB = Presiunea max. de lucru - Ø d2 = diametru exterior țevă

Variante produs

XVU	Racord filetat tip tată, Oțel
VU VA	Racord filetat tip tată, oțel inoxidabil