

# W90 IR HJ

Ștuț de legătură, IGR AGJ unghi 90°

**HANSA FLEX**

## Caracteristici

Racord 1	Filete cilindrice interioare BSP
Formă de etanșare 1	cu etanșare pe suprafață
Racord 2	Filete UN/UNF exterioare
Formă de etanșare 2	Con exterior 74°
Tip constructiv	Ștuț de legătură
Forma constructivă	Racord 90°
Material	Oțel
Protecția suprafeței	acoperire galvanică

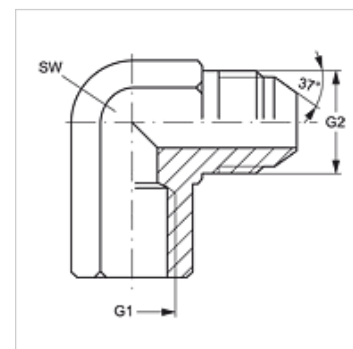

## Articol

Denumire	G1	G2	SW (mm)
W90 IR 02 HJ 04	G 1/8" -28	7/16" -20 UNF	14
W90 IR 02 HJ 05	G 1/8" -28	1/2" -20 UNF	14
W90 IR 04 HJ	G 1/4" -19	7/16" -20 UNF	19
W90 IR 04 HJ 05	G 1/4" -19	1/2" -20 UNF	19
W90 IR 04 HJ 06	G 1/4" -19	9/16" -18 UNF	19
W90 IR 04 HJ 08	G 1/4" -19	3/4" -16 UNF	19
W90 IR 06 HJ	G 3/8" -19	9/16" -18 UNF	22
W90 IR 06 HJ 08	G 3/8" -19	3/4" -16 UNF	22
W90 IR 08 HJ	G 1/2" -14	3/4" -16 UNF	27
W90 IR 08 HJ 10	G 1/2" -14	7/8" -14 UNF	27
W90 IR 08 HJ 12	G 1/2" -14	1.1/16" -12 UN	27
W90 IR 12 HJ	G 3/4" -14	1.1/16" -12 UN	33
W90 IR 16 HJ	G 1" -11	1.5/16" -12 UN	41
W90 IR 16 HJ 20	G 1" -11	1.5/8" -12 UN	48
W90 IR 20 HJ	G 1.1/4" -11	1.5/8" -12 UN	48

SW = deschiderea cheii