

# WSA HJ

Adaptor de sudare, unghi 90°

**HANSA FLEX**

## Caracteristici

Racord 1	Ștuțuri de fixat prin sudură
Racord 2	Filete UN/UNF exterioare
Formă de etanșare 2	Con exterior 74°
Tip constructiv	Adaptoare fixate prin sudură
Forma constructivă	Racord 90°
Material	Oțel
Protecția suprafeței	fosfatat și uns (Znphr5f)

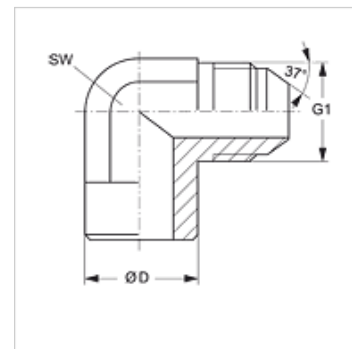
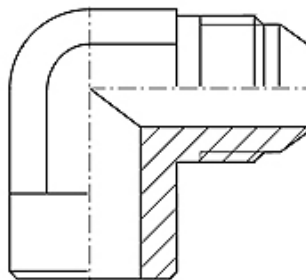

## Articol

Denumire	G1	Ø D (mm)	SW (mm)
WSA 04 HJ 15	7/16" -20 UNF	15	11
WSA 05 HJ 15	1/2" -20 UNF	15	13
WSA 06 HJ 15	9/16" -18 UNF	15	14
WSA 08 HJ 20	3/4" -16 UNF	20	19
WSA 10 HJ 23	7/8" -14 UNF	23	22
WSA 12 HJ 28	1.1/16" -12 UN	28	27
WSA 14 HJ 34	1.3/16" -12 UN	34	33
WSA 16 HJ 35	1.5/16" -12 UN	35	33
WSA 20 HJ 42	1.5/8" -12 UN	42	41

SW = deschiderea cheii