

GFS STRE (3000 PSI)

Contraflanșă de sudură cap la cap SAE

Caracteristici

Seria de presiuni	3000 psi
Standard	SAE J 518 C ISO 6162
Tip constructiv - element suplimentar	ND 40
Forma constructivă	drept
Tip constructiv	Contraflanșă fixată prin sudură SAE
Fixare	filet interior pentru șuruburi metrice
Material	S355J2G3 (ST52.3)
Protecția suprafeței	uns negru

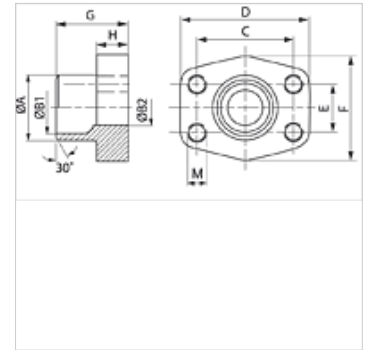

Indicație

Presiunea maximă de lucru indicată se referă la flanșă! Presiunea efectivă de lucru se determină în funcție de țevă (grosimea peretelui) și a calității țevii!

Articol

Denumire	PB 10.9 (bar)	Dimensiunea constructivă	Țevă	A (mm)	B1 (mm)	B2 (mm)	G (mm)	C (mm)	D (mm)	E (mm)	F (mm)	H (mm)	M metr.
GFS 80 STRE 21.3	350	1/2"	21,3 x 2,6	22,0	16,0	13	35,0	38,1	54	17,5	46	16,0	M 8
GFS 100 STRE 26.9	350	3/4"	26,9 x 2,6	28,0	21,5	19	35,0	47,6	65	22,2	50	18,0	M 10
GFS 102 STRE 33.7	315	1"	33,7 x 3,2	35,0	27,0	25	38,0	52,4	70	26,2	55	18,0	M 10
GFS 104 STRE 42.4	250	1.1/4"	42,4 x 3,2	43,0	36,0	31	41,0	58,7	79	30,2	68	21,0	M 10
GFS 106 STRE 48.3	200	1.1/2"	48,3 x 3,2	49,0	42,0	38	44,0	69,9	93	35,7	78	25,0	M 12
GFS 108 STRE 48.3	200	2"	48,3 x 3,2	49,0	42,0	42	45,0	77,8	102	42,9	90	25,0	M 12
GFS 108 STRE 60.3	200	2"	60,3 x 3,6	61,0	53,0	49	45,0	77,8	102	42,9	90	25,0	M 12
GFS 110 STRE 60.3	160	2.1/2"	60,3 x 3,6	61,0	53,0	53	50,0	88,9	114	50,8	105	25,0	M 12
GFS 110 STRE 76.1	160	2.1/2"	76,1 x 3,6	77,0	70,0	62	50,0	88,9	114	50,8	105	25,0	M 12
GFS 112 STRE 88.9	138	3"	88,9 x 3,6	90,0	82,0	74	51,0	106,4	134	61,9	124	26,0	M 16
GFS 114 STRE 76.1	35	3.1/2"	76,1 x 3,6	77,0	70,0	70	48,0	120,7	152	69,9	136	26,0	M 16
GFS 114 STRE 88.9	35	3.1/2"	88,9 x 3,6	90,0	82,0	82	48,0	120,7	152	69,9	136	26,0	M 16
GFS 116 STRE 114	35	4"	114,3 x 3,6	115,0	107,0	102	48,0	130,2	162	77,8	146	26,0	M 16
GFS 116 STRE 88.9	35	4"	88,9 x 3,6	90,0	82,0	82	48,0	130,2	162	77,8	146	26,0	M 16
GFS 118 STRE 139	35	5"	139,7 x 4	140,2	131,0	120	50,0	152,4	184	92,1	180	28,0	M 16

PN = Presiunea nominală PB = Presiunea max. de lucru