

WN VA

Racord filetat tip tată, 90°

HANSA FLEX

Caracteristici

Racord 1	Filete NPT exterioare
Formă de etanșare 1	cu etanșare pe filet
Racord 2	Filet metric exterior cilindric
Formă de etanșare 2	Con interior 24°
Tip constructiv	Racord filetat tip tată
Forma constructivă	Racord 90°
Standard	DIN 2353 ISO 8434-1
Set de livrare	Ștuț cu piuliță olandeză și inel de tăiere
Material	oțel inoxidabil

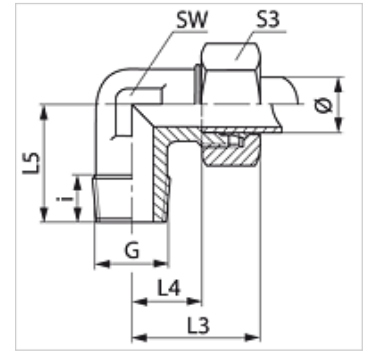

Indicație

Indicațiile privind montajul, asamblarea, încărcarea cu presiune și temperaturile de regim admisibile se găsesc în informațiile tehnice referitoare la îmbinările filetate pentru țevi.

Articol

Denumire	Seria	Presiune de lucru bar	Ø exterior țevă (mm)	G	i (mm)	L3 (mm)	L4 (mm)	L5 (mm)	SW (mm)	S3
WN 04 LL VA	LL	PN 100	4	1/8" -27 NPT	7,0	21	11,0	17	9	10
WN 06 LL VA	LL	PN 100	6	1/8" -27 NPT	10,0	21	9,5	17	9	12
WN 08 LL VA	LL	PN 100	8	1/8" -27 NPT	10,0	21	9,5	17	12	14
WN NW 04 HL VA	L	PN 315	6	1/8" -27 NPT	10,0	27	12,0	20	12	14
WN NW 04 HL 1/4 VA	L	PN 315	6	1/4" -18 NPT	12,0	29	14,0	26	12	14
WN NW 04 HL 3/8 VA	L	PN 315	6	3/8" -18 NPT	15,3	33	18,0	28	14	14
WN NW 04 HL 1/2 VA	L	PN 315	6	1/2" -14 NPT	17,0	38	23,0	34	19	14
WN NW 06 HL 1/8 VA	L	PN 315	8	1/8" -27 NPT	110,0	29	14,0	26	12	17
WN NW 06 HL VA	L	PN 315	8	1/4" -18 NPT	12,0	29	14,0	26	12	17
WN NW 06 HL 3/8 VA	L	PN 315	8	3/8" -18 NPT	15,2	23	11,5	20	12	17
WN NW 06 HL 1/2 VA	L	PN 315	8	1/2" -14 NPT	17,5	30	15,0	26	12	17
WN NW 08 HL 1/8 VA	L	PN 315	10	1/8" -27 NPT	10,0	30	15,0	27	14	19
WN NW 08 HL VA	L	PN 315	10	1/4" -18 NPT	14,0	30	15,0	27	14	19
WN NW 08 HL 3/8 VA	L	PN 315	10	3/8" -18 NPT	15,2	30	15,0	27	14	19
WN NW 08 HL 1/2 VA	L	PN 315	10	1/2" -14 NPT	20,0	37	21,0	33	17	19
WN NW 10 HL 1/4 VA	L	PN 315	12	1/4" -18 NPT	14,0	32	17,0	28	17	22
WN NW 10 HL VA	L	PN 315	12	3/8" -18 NPT	12,5	32	17,0	28	17	22
WN NW 10 HL 1/2 VA	L	PN 315	12	1/2" -14 NPT	19,0	38	23,0	34	19	22
WN NW 13 HL 3/8 VA	L	PN 315	15	3/8" -18 NPT	13,0	36	21,0	34	19	27
WN NW 13 HL VA	L	PN 315	15	1/2" -14 NPT	18,5	36	21,0	34	19	27
WN NW 16 HL 3/8 VA	L	PN 315	18	3/8" -18 NPT	15,3	40	23,5	36	24	32
WN NW 16 HL VA	L	PN 315	18	1/2" -14 NPT	20,0	40	23,5	36	24	32
WN NW 16 HL 3/4 VA	L	PN 315	18	3/4" -14 NPT	18,5	40	23,5	40	24	32
WN NW 20 HL 1/2 VA	L	PN 160	22	1/2" -14 NPT	20,0	44	27,5	42	27	36
WN NW 20 HL VA	L	PN 160	22	3/4" -14 NPT	18,5	44	27,5	42	27	36
WN NW 25 HL 3/4 VA	L	PN 160	28	3/4" -14 NPT	20,0	47	30,5	48	36	41
WN NW 25 HL VA	L	PN 160	28	1" -11,5 NPT	24,0	47	30,5	48	36	41
WN NW 32 HL VA	L	PN 160	35	1.1/4" -11,5 NPT	25,5	56	34,5	54	41	50
WN NW 40 HL VA	L	PN 160	42	1.1/2" -11,5 NPT	26,0	63	40,0	61	50	60
WN NW 03 HS VA	S	PN 630	6	1/4" -18 NPT	12,0	31	16,0	26	12	17
WN NW 03 HS 3/8 VA	S	PN 630	6	3/8" -18 NPT	15,3	32	17,5	27	14	17
WN NW 03 HS 1/2 VA	S	PN 630	6	1/2" -14 NPT	20,0	36	21,0	34	17	17
WN NW 04 HS VA	S	PN 630	8	1/4" -18 NPT	15,0	32	17,0	27	14	19
WN NW 04 HS 3/8 VA	S	PN 630	8	3/8" -18 NPT	15,3	33	18,0	28	14	19
WN NW 04 HS 1/2 VA	S	PN 630	8	1/2" -14 NPT	20,0	38	23,0	34	17	19
WN NW 06 HS 1/4 VA	S	PN 630	10	1/4" -18 NPT	15,0	34	17,5	28	17	22
WN NW 06 HS VA	S	PN 630	10	3/8" -18 NPT	12,0	34	17,5	28	17	22
WN NW 06 HS 1/2 VA	S	PN 630	10	1/2" -14 NPT	20,0	39	22,5	32	17	22
WN NW 08 HS 1/4 VA	S	PN 630	12	1/4" -18 NPT	15,0	38	21,5	29	17	24
WN NW 08 HS VA	S	PN 630	12	3/8" -18 NPT	12,5	38	21,5	28	17	24
WN NW 08 HS 1/2 VA	S	PN 630	12	1/2" -14 NPT	20,0	39	21,5	34	17	24
WN NW 10 HS 3/8 VA	S	PN 630	14	3/8" -18 NPT	15,3	40	22,0	30	19	27

În pofida controlului minuțios nu putem exclude eventualele informații eronate și nu garantăm pentru datele cuprinse.

WN VA

Racord filetat tip tată, 90°

HANSA FLEX

Articol

Denumire	Seria	Presiune de lucru bar	Ø exterior țevă (mm)	G	i (mm)	L3 (mm)	L4 (mm)	L5 (mm)	SW (mm)	S3
WN NW 10 HS VA	S	PN 630	14	1/2" -14 NPT	18,0	40	22,0	34	19	27
WN NW 13 HS 3/8 VA	S	PN 400	16	3/8" -18 NPT	15,3	43	24,5	32	24	30
WN NW 13 HS VA	S	PN 400	16	1/2" -14 NPT	19,0	43	24,5	36	24	30
WN NW 13 HS 3/4 VA	S	PN 400	16	3/4" -14 NPT	20,0	43	25,0	40	24	30
WN NW 16 HS 1/2 VA	S	PN 400	20	1/2" -14 NPT	20,0	48	26,5	42	27	36
WN NW 16 HS VA	S	PN 400	20	3/4" -14 NPT	20,0	48	26,6	42	27	36
WN NW 20 HS VA	S	PN 400	25	1" -11,5 NPT	24,0	54	30,0	48	36	46
WN NW 25 HS VA	S	PN 400	30	1.1/4" -11,5 NPT	25,5	62	35,5	54	41	50
WN NW 32 HS VA	S	PN 315	38	1.1/2" -11,5 NPT	26,0	72	41,0	61	50	60

PN = Presiunea nominală PB = Presiunea max. de lucru - Seria: LL = foarte ușoară L = ușoară S = grea - Ø = Diametrul exterior al țevii

Variante produs

WN	Racord filetat tip tată, 90°, Oțel
WN MG	Racord filetat tip tată, 90°, Alamă
XWN VA	Racord filetat tip tată, 90°, oțel inoxidabil