

Caracteristici

Racord 1	Filete conice exterioare BSPT
Formă de etanșare 1	cu etanșare pe filet
Racord 2	Filet metric exterior cilindric
Formă de etanșare 2	Con interior 24°
Tip constructiv	Racord filetat tip tată
Forma constructivă	Racord 90°
Standard	DIN 2353 ISO 8434-1
Set de livrare	Ștuț cu piuliță olandeză și inel de tăiere
Material	Oțel
Protecția suprafeței	acoperire galvanică

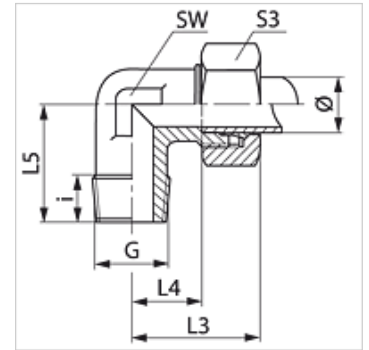

Indicație

Indicațiile privind montajul, asamblarea, încărcarea cu presiune și temperaturile de regim admisibile se găsesc în informațiile tehnice referitoare la îmbinările filetate pentru țevi.

Articol

Denumire	Seria	Presiune de lucru bar	Ø exterior țevă (mm)	G	i (mm)	L3 (mm)	L4 (mm)	L5 (mm)	SW (mm)	S3
WR 04 LL	LL	PN 100	4	R 1/8" K	8	21	11,0	18	11	10
WR 05 LL	LL	PN 100	5	R 1/8" K	8	22	10,0	17	11	12
WR 06 LL	LL	PN 100	6	R 1/8" K	8	22	10,0	17	11	12
WR 08 LL	LL	PN 100	8	R 1/8" K	8	23	11,5	20	12	14
WR 10 LL	LL	PN 100	10	R 1/4" K	12	27	15,5	26	14	17
WR 12 LL	LL	PN 100	12	R 1/4" K	12	27	15,0	27	17	19
WR NW 04 HL	L	PN 315	6	R 1/8" K	8	27	12,0	20	12	14
WR NW 04 HL 1/4	L	PN 315	6	R 1/4" K	12	29	14,0	26	12	14
WR NW 04 HL 3/8	L	PN 315	6	R 3/8" K	12	29	14,0	26	12	14
WR NW 06 HL 1/8	L	PN 315	8	R 1/8" K	8	29	14,0	26	12	17
WR NW 06 HL	L	PN 315	8	R 1/4" K	12	29	14,0	26	12	17
WR NW 06 HL 3/8	L	PN 315	8	R 3/8" K	12	34	19,0	28	17	17
WR NW 06 HL 1/2	L	PN 315	8	R 1/2" K	13	34	19,0	30	17	17
WR NW 08 HL 1/8	L	PN 315	10	R 1/8" K	8	30	15,0	26	14	19
WR NW 08 HL	L	PN 315	10	R 1/4" K	12	30	15,0	27	14	19
WR NW 08 HL 3/8	L	PN 315	10	R 3/8" K	12	32	17,0	28	17	19
WR NW 08 HL 1/2	L	PN 316	10	R 1/2" K	14	38	23,0	34	19	19
WR NW 10 HL 1/4	L	PN 315	12	R 1/4" K	12	32	17,0	28	17	22
WR NW 10 HL	L	PN 315	12	R 3/8" K	12	32	17,0	28	17	22
WR NW 10 HL 1/2	L	PN 315	12	R 1/2" K	14	38	23,0	34	19	22
WRK NW 10 HL 3/4	L	PN 315	12	R 3/4" K	14	36	21,0	34	19	22
WR NW 13 HL 1/4	L	PN 315	15	R 1/4" K	12	36	21,0	30	19	27
WR NW 13 HL 3/8	L	PN 315	15	R 3/8" K	12	36	21,0	34	19	27
WR NW 13 HL	L	PN 315	15	R 1/2" K	14	36	21,0	34	19	27
WR NW 16 HL 3/8	L	PN 315	18	R 3/8" K	12	40	23,5	34	24	32
WR NW 16 HL	L	PN 315	18	R 1/2" K	14	40	23,5	36	24	32
WR NW 16 HL 3/4	L	PN 160	18	R 3/4" K	16	36	27,5	44	27	32
WRK NW 20 HL	L	PN 160	22	R 3/4" K	16	44	27,5	31	27	36
WR NW 03 HS	S	PN 400	6	R 1/4" K	12	31	16,0	26	12	17
WR NW 04 HS	S	PN 400	8	R 1/4" K	12	32	17,0	27	17	19
WR NW 06 HS	S	PN 400	10	R 3/8" K	12	34	17,5	28	17	22
WR NW 08 HS	S	PN 400	12	R 3/8" K	12	38	21,5	28	17	24
WR NW 08 HS 1/2	S	PN 400	12	R 1/2" K	14	40	23,5	34	19	24
WR NW 10 HS	S	PN 400	14	R 1/2" K	14	40	22,0	32	19	27
WR NW 13 HS	S	PN 400	16	R 1/2" K	14	43	24,5	32	24	30
WR NW 13 HS 3/8	S	PN 400	16	R 3/8" K	12	43	24,5	32	24	30
WR NW 16 HS 1/2	S	PN 400	20	R 1/2" K	14	48	26,5	42	27	36

Seria: LL = foarte ușoară L = ușoară S = grea - PN = Presiunea nominală PB = Presiunea max. de lucru - Ø = Diametrul exterior al țevii



Variante produs

WRK MG	Racord filetat tip tată, 90°, Alama
---------------	-------------------------------------

WRK VA	Racord filetat tip tată, 90°, oțel inoxidabil
---------------	---

XWRK	Racord filetat tip tată, 90°, Oțel
-------------	------------------------------------