

## Caracteristici

<b>Utilizare</b>	Conducte cu agent de răcire și lubrifiant pentru prelucrarea metalelor prin așchiere.
<b>Execuție</b>	Spirală-suport din oțel cu furtun interior din PVC es. Pivotal filetat as. Duză de evacuare din oțel Suprafață nichelată
<b>Caracteristici</b>	complet etanș se poate îndoi manual, în aproape orice poziție stabilitate rezistență la uleiuri, grăsimi etc.

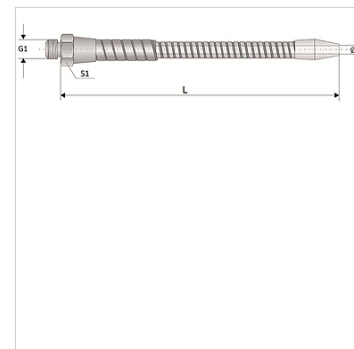

## Indicații referitoare comandă

Alte dimensiuni la cerere

## Articol

Denumire	G1	ID (mm)	S1 (mm)	Lungime nominală (+/-5 mm)
NIAG 1/8-200	R 1/8"	8,0	15,0	200
NIAG 1/8-250	R 1/8"	8,0	15,0	250
NIAG 1/8-320	R 1/8"	8,0	15,0	320
NIAG 1/8-400	R 1/8"	8,0	15,0	400
NIAG 1/8-500	R 1/8"	8,0	15,0	500
NIAG 1/8-630	R 1/8"	8,0	15,0	630
NIAG 1/8-800	R 1/8"	8,0	15,0	800
NIAG 1/4-200	R 1/4"	10,0	19,0	200
NIAG 1/4-250	R 1/4"	10,0	19,0	250
NIAG 1/4-320	R 1/4"	10,0	19,0	320
NIAG 1/4-400	R 1/4"	10,0	19,0	400
NIAG 1/4-500	R 1/4"	10,0	19,0	500
NIAG 1/4-630	R 1/4"	10,0	19,0	630
NIAG 1/4-800	R 1/4"	10,0	19,0	800
NIAG 3/8-250	R 3/8"	10,0	24,0	250
NIAG 3/8-300	R 3/8"	10,0	24,0	300
NIAG 3/8-320	R 3/8"	10,0	24,0	320
NIAG 3/8-400	R 3/8"	10,0	24,0	400
NIAG 3/8-500	R 3/8"	10,0	24,0	500
NIAG 3/8-630	R 3/8"	10,0	24,0	630
NIAG 3/8-800	R 3/8"	10,0	24,0	800
NIAG 1/2-250	R 1/2"	12,0	27,0	250
NIAG 1/2-320	R 1/2"	12,0	27,0	320
NIAG 1/2-400	R 1/2"	12,0	27,0	400
NIAG 1/2-500	R 1/2"	12,0	27,0	500
NIAG 1/2-630	R 1/2"	12,0	27,0	630
NIAG 1/2-800	R 1/2"	12,0	27,0	800