

Caracteristici

Tip montură	Montură fără exfoliere
adekvat pentru	2TE (TE 200, TE 200B) 3TE (TE 300) SI 200 RME
Material	Oțel
Protecția suprafeței	acoperire galvanică

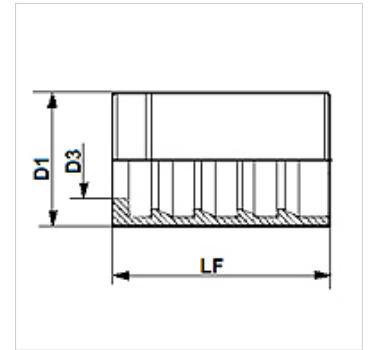
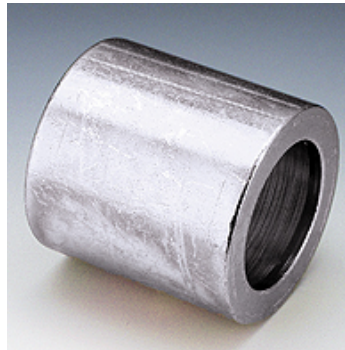

Indicație

Tipul de montură alocat depinde de tipul furtunului.

PHT204 pentru 2TE (TE200, TE200B)

PHT304 pentru 3TE (TE300)

Articol

Denumire	DN*	Dimensiune	Țol	D1 (mm)	D3 (mm)	LF (mm)
PHT 204	5	3	3/16"	17,0	9,8	27,3
PHT 304	5	3	3/16"	18,6	9,8	27,3
PHT 06	6	4	1/4"	19,0	11,6	28,0
PHT 08	8	5	5/16"	22,3	12,6	30,2
PHT 10	10	6	3/8"	23,0	14,9	29,5
PHT 13	12	8	1/2"	27,0	18,5	31,0
PHT 16	16	10	5/8"	32,0	21,8	33,0
PHT 20	19	12	3/4"	35,0	24,6	37,5
PHT 25	25	16	1"	42,0	30,8	45,5
PHT 32	31	20	1.1/4"	48,0	37,9	55,0
PHT 40	38	24	1.1/2"	57,2	44,2	63,2
PHT 50	51	32	2"	76,0	56,8	78,5

DN = diametru nominal